

Model TN-17 16.8 (K240) K-factor Horizontal Spray Nozzle, Open

IMPORTANT

Refer to Technical Data Sheet TFP2300 for warnings pertaining to regulatory and health information. Always refer to Technical Data Sheet TFP700 for the "INSTALLER WARNING" that provides cautions with respect to handling and installation of sprinkler systems and components. Improper handling and installation can permanently damage a sprinkler system or its components and cause the sprinkler to fail to operate in a fire situation or cause it to operate prematurely.

Scan the QR code or enter the URL in a web browser to access the most up-to-date electronic version of this document. Data rates may apply.



docs.jci.com/tycofire/TFP852

General Description

The TYCO Model TN-17 Horizontal Spray Nozzle having a 16.8 (K240) K-factor is a specialized open nozzle for use in tunnel fire protection deluge systems, providing an improved alternative to traditional designs. With its ability to provide extended coverage, the Model TN-17 Nozzle allows for a single pipe to run the length of a tunnel, compared to traditional designs that use multiple pipes in order to provide sufficient coverage. The Model TN-17 Nozzle is an open nozzle designed to be integrated into a deluge fire protection system.

The Model TN-17 Nozzle provides protection of coverage areas up to 16 ft 4 in. x 32 ft 8 in. (5,0 m x 10,0 m) as compared to standard coverage sprinklers often used in tunnel fire protection system designs having a maximum coverage area of 10 ft x 10 ft (3,0 m x 3,0 m).

NOTICE

The TYCO Model TN-17 Horizontal Spray Nozzle described herein must be installed and maintained in compliance with this document and with the applicable standards recognized by any authorities having jurisdiction. Failure to do so may impair the performance of these devices.

The design of individual fixed water spray systems for fire protection can vary considerably, depending on the characteristics and nature of the hazard, the basic purpose of the spraying system, the configuration of the hazard, and wind/draft/ventilation conditions. Because of these variations, the design of fixed water spray systems must only be performed by experienced designers who thoroughly understand the limitations as well as capabilities of such systems.

The Tunnel Operator is responsible for maintaining their fire protection system and devices in proper operating condition. Contact the installing contractor or product manufacturer with any questions.

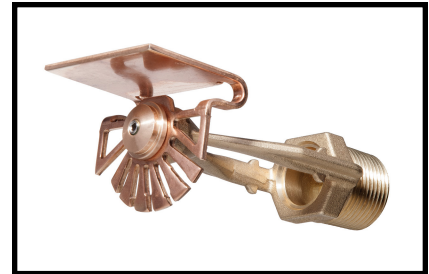

Technical Data

Approvals

UL and C-UL Listed

Minimum Working Pressure

10 psi (0,7 bar)

Maximum Working Pressure

30 psi (2,1 bar)

Pipe Thread Connections

3/4 in. NPT or ISO 7-R 3/4

Discharge Coefficient

K=16.8 gpm/psi^{1/2} (241,9 Lpm/bar^{1/2})

Finish

Natural Brass

Physical Characteristics

Frame	Brass
Deflector Screw	Stainless Steel
Deflector	Brass
Deflector Nut	Bronze

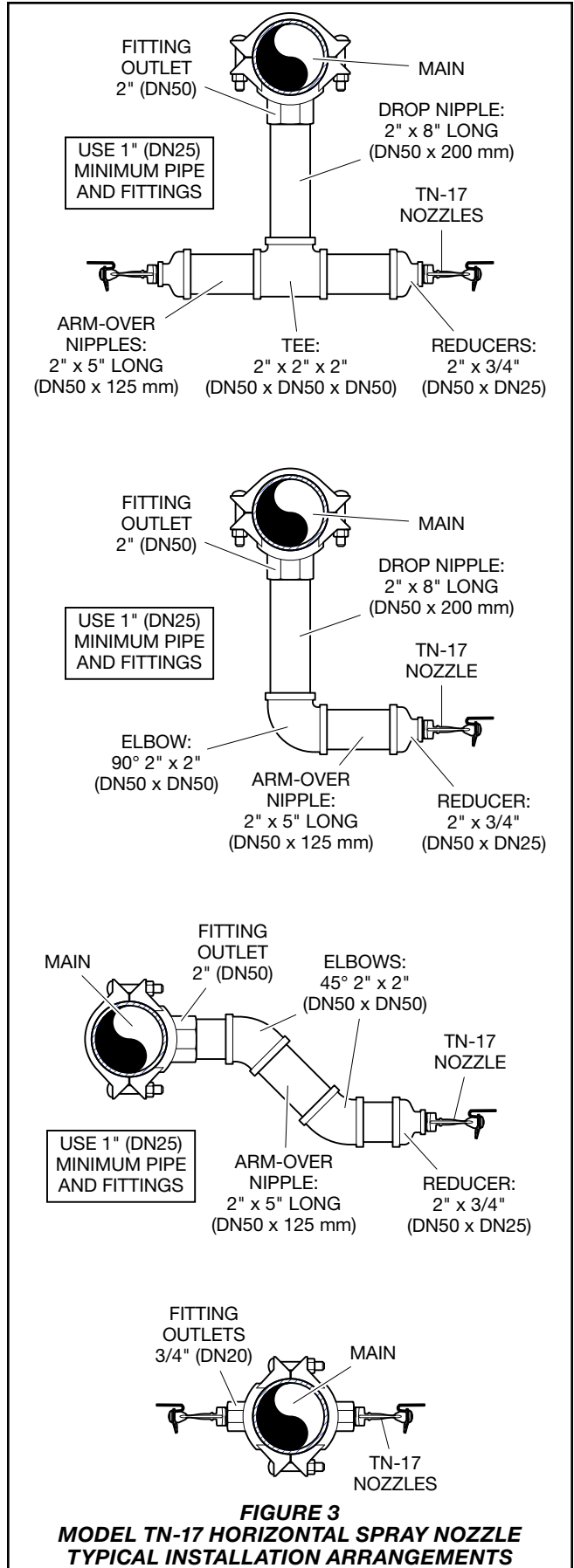
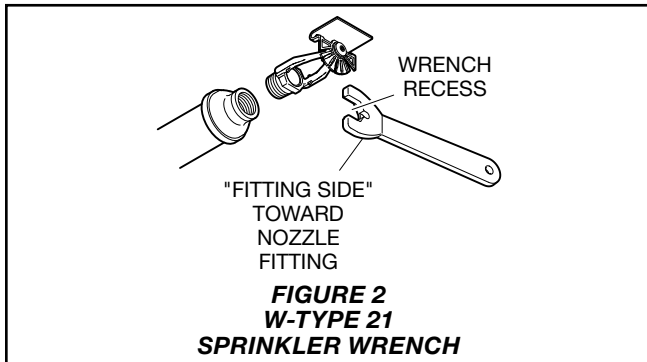
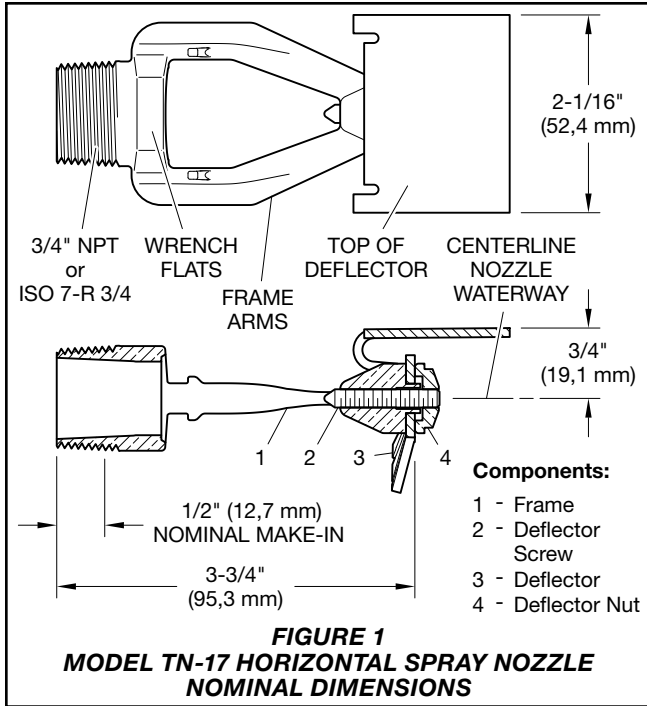

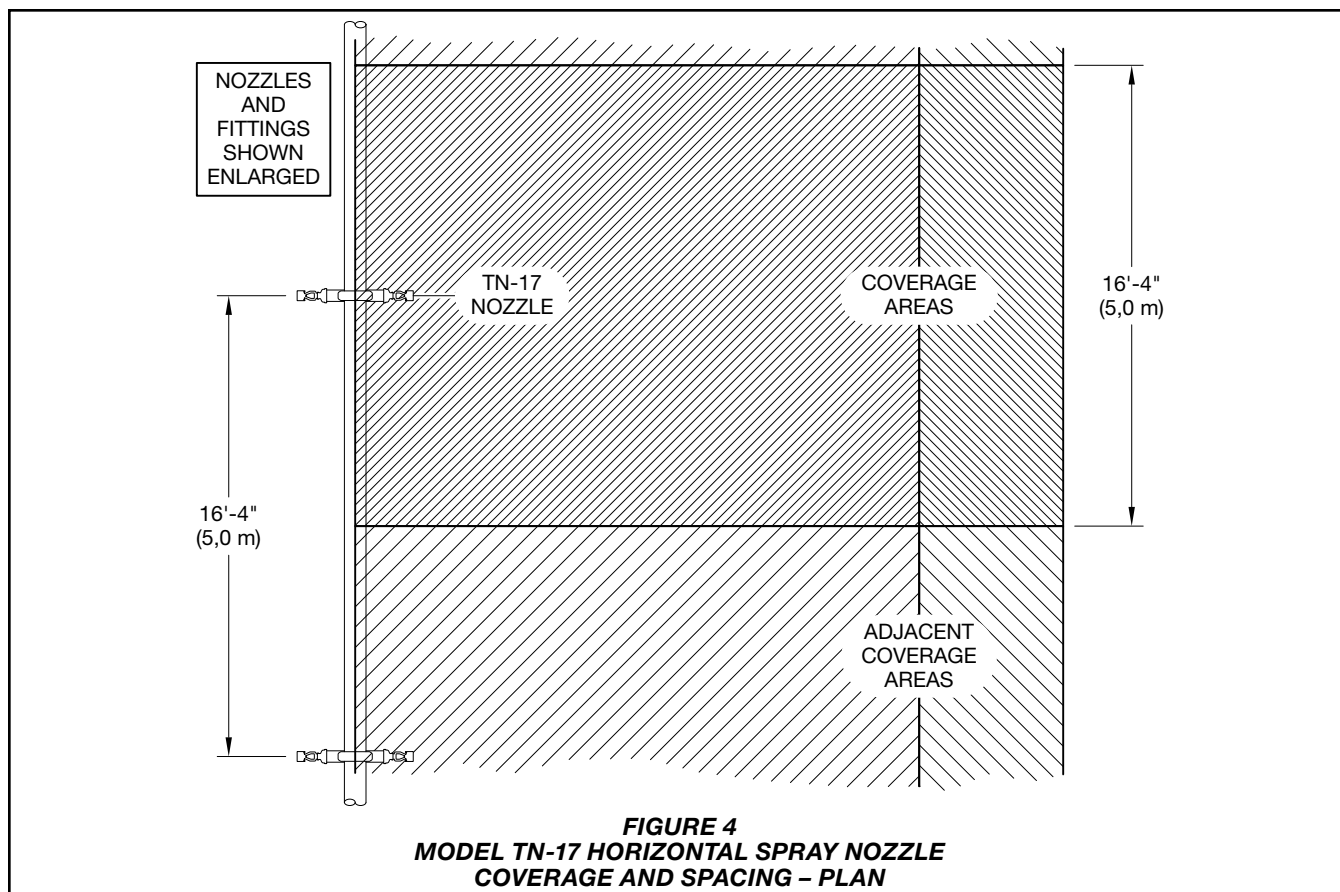

Design Criteria

The TYCO Model TN-17 K=16.8 Horizontal Spray Nozzle is intended for integration into a water spray, deluge fire protection system designed in accordance with the applicable standards recognized by any authorities having jurisdiction.

Nozzle Orientation

The Model TN-17 Nozzle must be installed in a horizontal orientation. See Figures 1 and 3.

Corrosion Resistance

It is recommended that the Tunnel Operator be consulted with respect to the suitability of the materials of construction and finish for any given corrosive environment. The effects of ambient temperature, concentration of chemicals, and gas/chemical velocity, should be considered, at a minimum, along with the corrosive nature to which the nozzles may be exposed.

The pipe, fittings, hangers, and hanger components must be suitable for use in the application environment.

Obstructions

The maximum allowable vertical and horizontal distance that the bottom of an obstruction can be away from the Model TN-17 Nozzle is provided in Graph A.

Non-continuous suspended obstructions such as air handlers, lights, and the like are to meet the "4x rule" of Figure 7; within 5 ft (152,4 cm) of the nozzle deflector in the area below the nozzle, the obstruction must be located four (4) times the longest dimension of the obstruction as defined in Figure 6, to a maximum of 60 in. (152,4 cm). No obstructions are allowed to be located within the designated shaded region. Care must be taken to place large obstructions running parallel to the nozzle discharge, such as signs, in the areas between the nozzles.

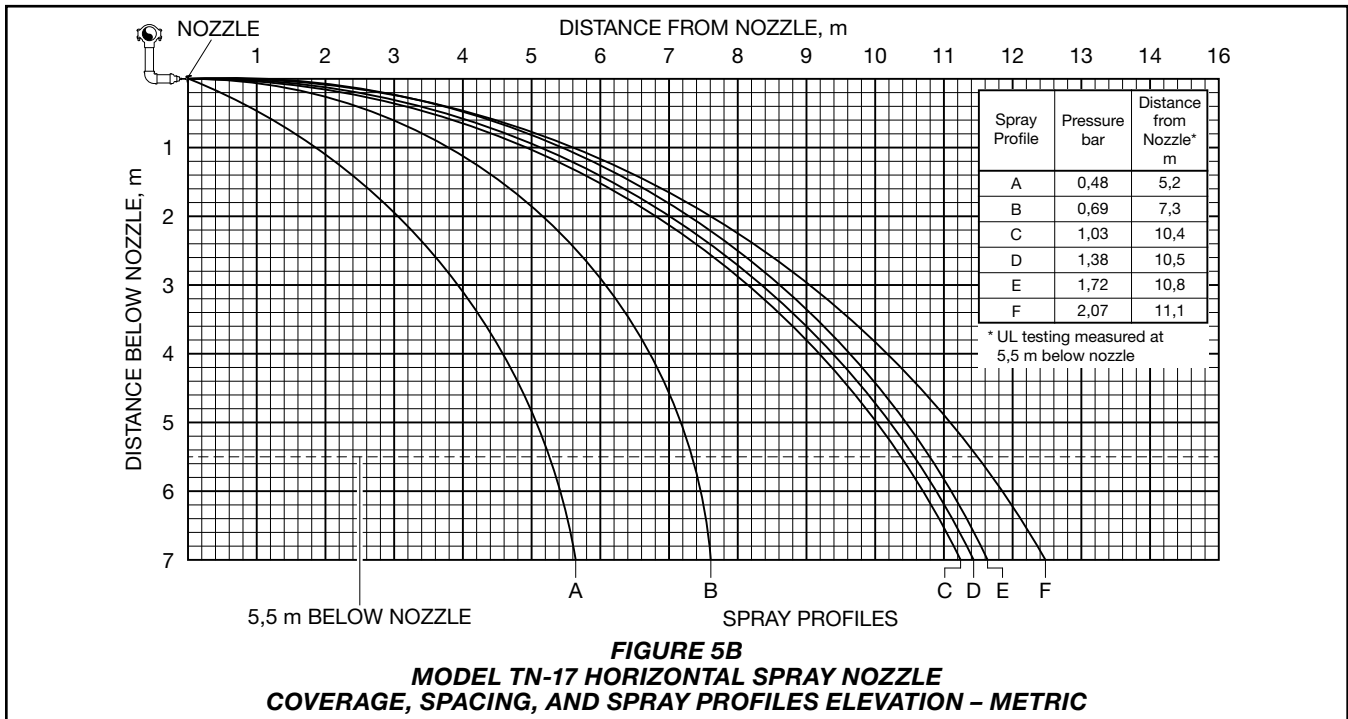
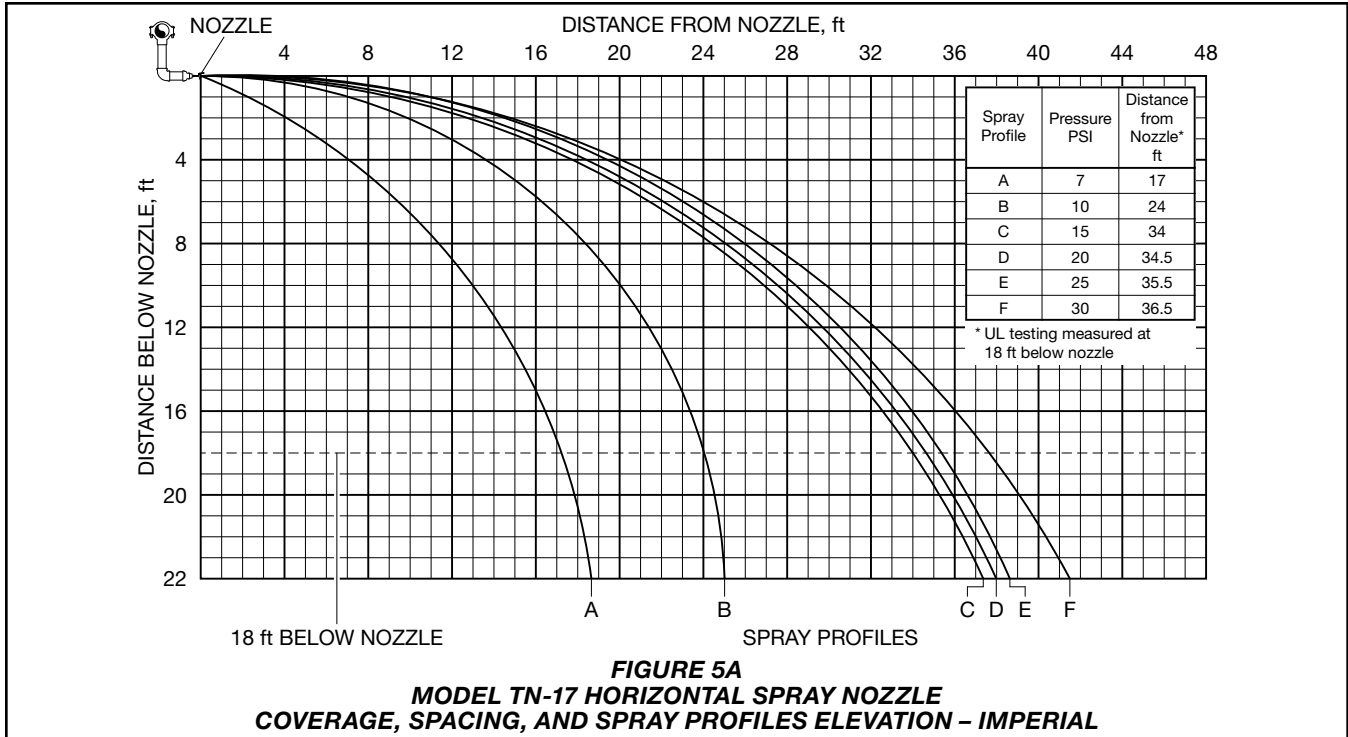

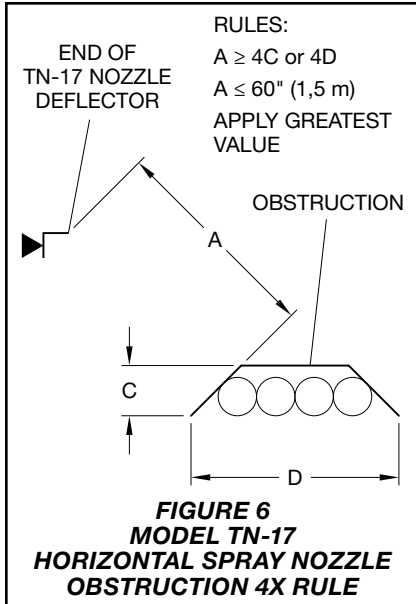

NOTES:

1. 0 = CENTERLINE OF NOZZLE
2. OBSTRUCTIONS WITHIN AREA 5'-0" (1,5 m) SPHERICAL RADIUS BELOW TOP OF NOZZLE DEFLECTOR MUST BE LOCATED MINIMUM 4 TIMES LONGEST DIMENSION OF OBSTRUCTION FROM END OF DEFLECTOR (REF. FIGURE 6)
3. OBSTRUCTIONS ALLOWED IN AREA ABOVE AND BELOW NOZZLE DEFLECTOR AS DEFINED ON ELEVATION VIEW
4. PLACE LARGE OBSTRUCTIONS (SIGNS, ETC.) PARALLEL TO NOZZLE DISCHARGE IN AREAS BETWEEN NOZZLES

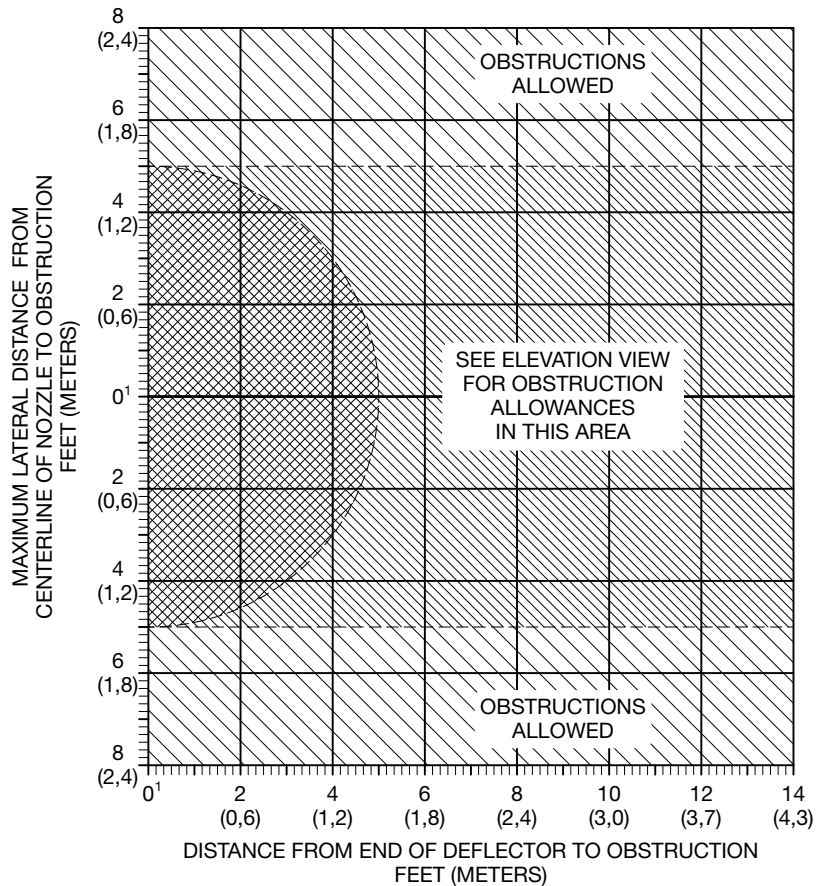

PLAN VIEW

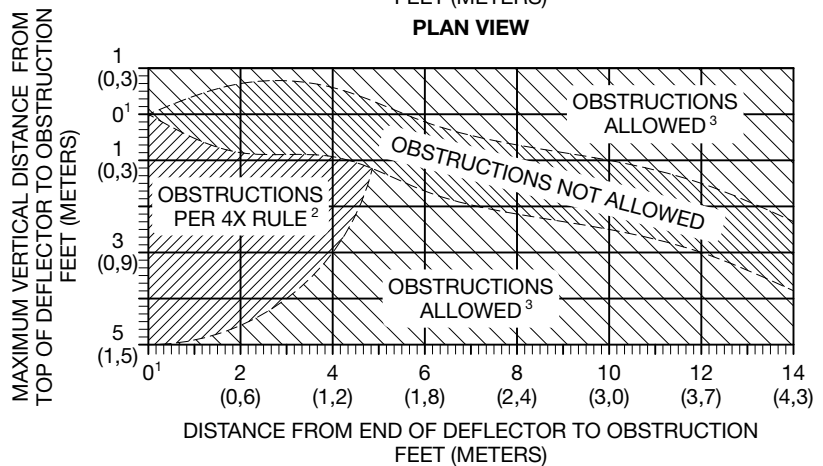

ELEVATION VIEW

GRAPH A
MODEL TN-17 HORIZONTAL SPRAY NOZZLE
OBSTRUCTION DATA

Installation

The TYCO Model TN-17 K=16.8 Horizontal Spray Nozzle, as shown in Figures 1 and 2, must be installed in accordance with this section.

NOTICE

The Model TN-17 Nozzle must be installed in accordance with the pipe dimensions shown in Figure 3. Failure to do so will impair the intended performance of the system.

General Instructions

The Model TN-17 Nozzle is to be oriented horizontally with the plane created by its two frame arms parallel with the ceiling or parallel with the finished grade, in the case of a non-flat ceiling.

Step 1. Ensure all piping components are properly assembled as shown in Figure 3 prior to installing the Model TN-17 Nozzle.

Step 2. With pipe-thread sealant applied to the nozzle threads, hand-tighten the Model TN-17 Nozzle into the Reducer.

Step 3. The Model TN-17 Nozzle must be tightened using only the W-Type 21 Sprinkler Wrench as shown in Figure 2. Fully engage the nozzle wrench flats as shown in Figure 1 and wrench tighten. A leak-tight 3/4 in. NPT or ISO 7-R 3/4 sprinkler joint should be obtained by applying a minimum-to-maximum torque of 20 to 30 ft-lb (26,8 to 40,2 N·m). Higher levels of torque can distort the nozzle inlet with consequent leakage or impairment of the nozzle. Ensure the markings on the deflector face towards the ceiling.

Care and Maintenance

The TYCO Model TN-17 K=16.8 Horizontal Spray Nozzle must be maintained and serviced in accordance with this section.

Before closing a fire protection system main control valve for maintenance work on the fire protection system that it controls, permission to shut down the affected fire protection system must be obtained from the proper authorities and notify all personnel who may be affected by this action.

Nozzles which are exhibiting visible signs of corrosion must be replaced.

Care must be exercised to avoid damage to the nozzles before, during, and after installation. Nozzles damaged by dropping, striking, wrench twist/slip-page, or the like, must be replaced. See the Installation section for additional information.

The Tunnel Operator is responsible for the inspection, testing, and maintenance of their fire protection system and devices in compliance with this document, in addition to the standards of any authorities having jurisdiction. Contact the installing contractor or product manufacturer with any questions.

Fire protection systems are recommended to be inspected, tested, and maintained by a qualified Inspection Service in accordance with local requirements and/or national codes.

Limited Warranty

For warranty terms and conditions, visit www.tyco-fire.com.

Ordering Procedure

Contact your local distributor for availability. When placing an order, indicate the full product name and part number (P/N).

Model TN-17 Horizontal Spray Nozzle

Specify: Model TN-17 Horizontal Spray Nozzle, K=16.8, (specify) Thread Connection, P/N (specify):

ISO 7-R 3/4	49-017-2-001
3/4 in. NPT	49-017-2-002
ISO 7-R 3/4 w/ Dust Cap	49-017-3-001
3/4 in. NPT w/ Dust Cap	49-017-3-002

Sprinkler Wrench (separately ordered)

Specify: W-Type 21 Sprinkler Wrench, P/N 56-001-0-686