

## Model RSV-1 Residential Shut-Off Valve, Dual-Purpose Water Supply, Domestic and Fire Sprinkler System

### IMPORTANT

Refer to Technical Data Sheet TFP2300 for warnings pertaining to regulatory and health information.

Scan the QR code or enter the URL in a web browser to access the most up-to-date electronic version of this document. Data rates may apply.



[docs.jci.com/tycofire/TFP982](http://docs.jci.com/tycofire/TFP982)

### General Description

The TYCO Model RSV-1 Residential Shut-Off Valves are intended for use in dual-purpose residential water supply piping that serves both domestic and residential fire protection sprinkler system needs. The 1 Inch (DN25) Valve is intended for NFPA 13D system needs, whereas the 2 Inch (DN50) Valve is intended for systems designed in accordance with either NFPA 13, 13D, or 13R.

When a fire sprinkler operates, the Model RSV-1 Residential Shut-Off Valve automatically diverts the available water supply to the fire sprinkler system. Consequently, when the Model RSV-1 Valve is utilized, the system designer does not need to add the domestic flow demand to the fire sprinkler system flow demand, as would otherwise be required by NFPA 13D or 13R.

Consider use of the Model RSV-1 Residential Shut-Off Valve when either the water supply cannot adequately provide for both the domestic design demand and the fire sprinkler flow demand, or it is necessary to increase the effectiveness of the fire sprinkler system by automatically diverting the domestic flow.

The Model RSV-1 Residential Shut-Off Valve maximizes the effective use of an existing water supply. Therefore, in areas with limited water supplies, it may eliminate the need to add costly pumps, pressurized reservoirs, or electrically operated domestic shut-off valves. The Model RSV-1 Valve has a built-in check valve in the fire sprinkler system outlet that eliminates the need for a separate check valve. Also, the Model RSV-1 Valve automatically resets, thereby eliminating the need for valve disassembly after a fire sprinkler system test or operation.

### NOTICE

*The Model RSV-1 Residential Shut-Off Valves described herein must be installed and maintained in compliance with this document, as well as with the applicable standards of the National Fire Protection Association, in addition to the standards of any authorities having jurisdiction. Failure to do so may impair the integrity of this device.*

*The owner is responsible for maintaining their fire protection system and devices in proper operating condition. Contact the installing contractor or product manufacturer with any questions.*



### Technical Data

#### Approvals

UL and C-UL Listed  
Certified to all requirements of NSF/ANSI 61, Annex G and NSF/ANSI 372

**Note:** The 1 Inch (DN25) Model RSV-1 Residential Shut-Off Valve is suitable for use in water supply arrangements for residential fire sprinkler systems designed per NFPA 13D.

**Note:** The 2 Inch (DN50) Model RSV-1 Residential Shut-Off Valve is suitable for use in water supply arrangements for residential fire sprinkler systems designed per NFPA 13, 13D, or 13R.

#### Maximum Pressure

175 psi (12,1 bar)

#### Weight

1 Inch (DN25): 11 lbs. (5 kg)  
2 Inch (DN50): 29 lbs. (11 kg)

#### Pressure Loss

Refer to Graphs A and B

#### Patents

2 Inch (DN50) Model RSV-1 Valve Patent Pending

**Physical Characteristics**

<b>1 Inch (DN25) Valve</b>	
Body .....	Stainless Steel
Top and Bottom Cover .....	Stainless Steel
Upper Cap .....	Stainless Steel
Bottom Seal .....	Stainless Steel
Piston .....	Plastic*
Differential Ring .....	Plastic*
Sleeve .....	Plastic*
Upper and Lower Seals .....	EPDM
O-Rings .....	Buna-N
Piston Spring .....	Stainless Steel
Piston Screws .....	Stainless Steel
Cap Screw .....	Stainless Steel
<b>2 Inch (DN50) Valve</b>	
Body and Cover .....	Stainless Steel
Piston Insert .....	Stainless Steel
Bottom Seal .....	Stainless Steel
Piston Cover .....	Plastic*
Insert Sleeve .....	Plastic*
Piston Seal .....	EPDM
O-Rings .....	EPDM
Piston Spring .....	Stainless Steel
Piston Nut .....	Stainless Steel
Retainer Ring .....	Stainless Steel
* Glass Reinforced Polyphenylene Oxide	

**Design Criteria**

The TYCO Model RSV-1 Residential Shut-Off Valve must be installed vertically with the Water Supply Port at the bottom, the Fire Sprinkler Port at the top, and the Domestic Port at the side (Ref. Figures 4 and 5). Figure 1 shows the typical installation arrangement. Refer to the Installation section for additional design considerations.

**Water Supply Requirements**

**1 Inch (DN25) Valve**  
 In order for the 1 Inch (DN25) Model RSV-1 Valve to operate automatically upon sprinkler operation, the fire sprinkler system from the water main to the most hydraulically remote sprinkler must be designed to provide a minimum single sprinkler flow of 12.5 GPM (47,3 LPM) when the supply pressure at the main is at its minimum expected value.

The minimum single sprinkler flow rate of 12.5 GPM (47,3 LPM), required for use with the 1 Inch (DN25) Model RSV-1 Valve, does not take precedence over any more hydraulically demanding single sprinkler flow rate specified for the residential sprinklers in use.

When performing hydraulic design calculations for the fire sprinkler system, you need not account for the trickle flow through the 1 Inch (DN25) Model RSV-1 Valve By-Pass Restriction into the domestic system.

For the 1 Inch (DN25) Model RSV-1 Valve, the maximum water supply service line is 1 inch (DN25).

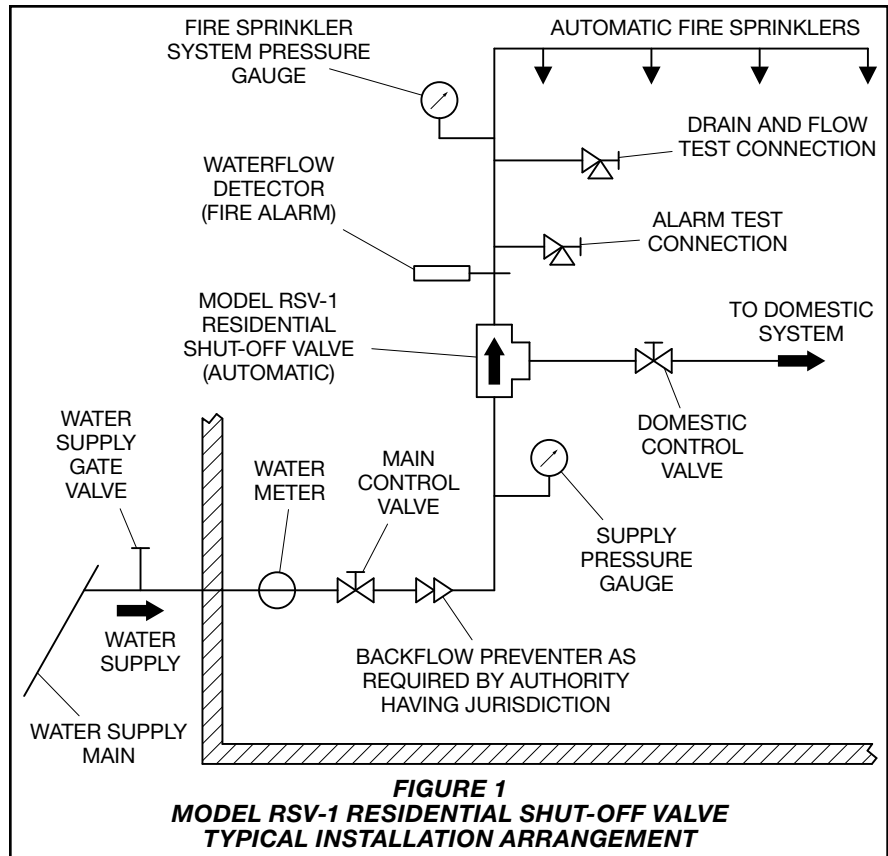

**FIGURE 1**  
**MODEL RSV-1 RESIDENTIAL SHUT-OFF VALVE**  
**TYPICAL INSTALLATION ARRANGEMENT**

**2 Inch (DN50) Valve**  
 In order for the 2 Inch (DN50) Model RSV-1 Valve to operate automatically at sprinkler activation, the fire sprinkler system from the water supply main to the most hydraulically remote sprinkler must be designed to provide a minimum single sprinkler flow of 8 GPM (30,5 LPM) when the water supply pressure at the water supply main is at its minimum expected value.

The minimum single sprinkler flow rate of 8 GPM (30,5 LPM), required for use with the 2 Inch (DN50) Model RSV-1 Valve, does not take precedence over any more hydraulically demanding single sprinkler flow rate specified for the residential sprinklers in use.

**Operating Principles**

When a fire sprinkler activates during domestic usage, the TYCO Model RSV-1 Residential Shut-Off Valve automatically diverts flow to the domestic system and diverts the available water supply to the fire sprinkler system, thereby eliminating a reduced flow condition in the sprinkler system that might otherwise be caused by possible significant domestic water usage.

When the Model RSV-1 Valve is in the normal standby position as shown in Figures 4 and 5, the Piston Assembly, assisted by its Spring, is in the down position. With the Piston Assembly in the down position, the Fire Sprinkler Seal permits the Model RSV-1 Valve to perform as a conventional check valve. Also, with the Piston Assembly in the down position, water is available on demand through the Domestic Flow Passage and out the Domestic Port.

Upon operation and with a minimum design water flow (e.g., 12.5 GPM (47,3 LPM) for the 1 inch Valve or 8 GPM (30,5 LPM) for the 2 Inch Valve) to the automatic residential fire sprinkler system, the Piston Assembly moves upward. With the Piston Assembly in the up position, any water flow to the Domestic Port is diverted to the Fire Sprinkler Port.

The contours of the Piston Assembly are specifically configured to minimize its upward movement except under the level of sustained fire sprinkler system flow resulting from operation of one or more fire sprinklers. However, because most fire sprinkler systems contain air pockets, the Piston Assembly tends to move momentarily upward when there is a surge in supply pressure.

The momentary opening and re-closing of the Piston Assembly at the Fire Sprinkler Line Seal traps a portion of the pressure of the pressure surge within the fire sprinkler system. Trapped pressure increases within the fire sprinkler system help to prevent a subsequent surge in the supply pressure from causing the water-flow detector to signal a false alarm.

As indicated above, domestic system usage can reduce the pressure available to the fire sprinkler system. However, when utilizing the Model RSV-1 Valve, you do not need to include additional hydraulic flow of the domestic system, when otherwise required by NFPA standards (NFPA 13D or 13R), to determine the minimum possible residual (flowing) pressure available to the fire sprinkler system.

For operation of the Model RSV-1 Residential Shut-Off Valve, you need only design the fire sprinkler system from the water supply main to the most hydraulically remote sprinkler. Domestic flow does not require consideration. As long as the single sprinkler flow is equal to or greater than 12.5 GPM (47,3 LPM) for the 1 Inch Valve or 8 GPM (30,5 LPM) for the 2 Inch Valve when the supply pressure at the main is at its minimum expected value, the Model RSV-1 Valve automatically diverts the domestic flow.

After the Piston Assembly has moved to the full up position, only a small amount of water is permitted to trickle through the Internal By-Pass Restriction to the Domestic Port (Ref. Figures 4 and 5). The trickle flow through the Internal By-Pass Restriction permits the Model RSV-1 Valve to reset automatically after a sprinkler operation or test without draining the fire sprinkler system.

When the Domestic Control Valve is closed, the Internal By-Pass Restriction allows the Supply and Domestic Port pressures to equalize and the Piston Assembly to move back down to the standby position.

When using the 1 inch RSV-1, the maximum flow rate through the Internal By-Pass Restriction, when the Model RSV-1 Valve is in the operated position, is no greater than 0.25 GPM (0,9 LPM) for a typical residual (flowing) pressure of 40 psi (2,8 bar) at the inlet. Consequently, when performing hydraulic design calculations for the fire sprinkler system, you do not need to consider trickle flow through the Model RSV-1 Valve Internal By-Pass Restriction into the domestic system.

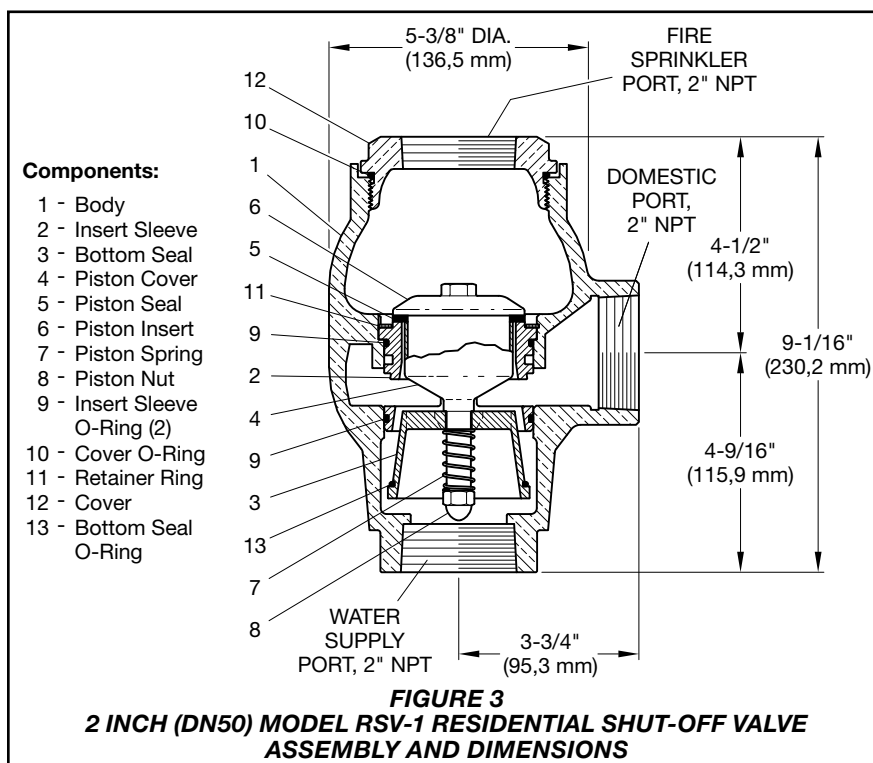
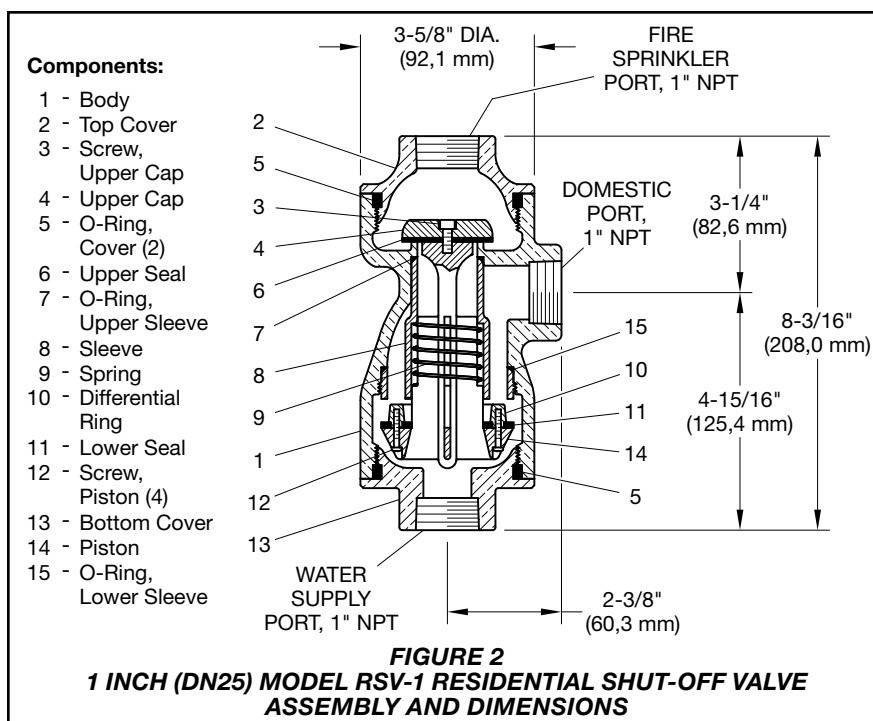

When using the 2 inch RSV-1, the maximum flow rate through the Internal By-Pass Restriction, when the Model RSV-1 Valve is in the operated position, is no greater than 1.5 GPM (5,7 LPM) for a typical residual (flowing) pressure of 40 psi (2,8 bar) at the inlet. Conse-

quently, when performing hydraulic design calculations for the fire sprinkler system, a 1.5 GPM (5,7 LPM) flow demand is required to be added at the RSV-1 and calculated back to the source.

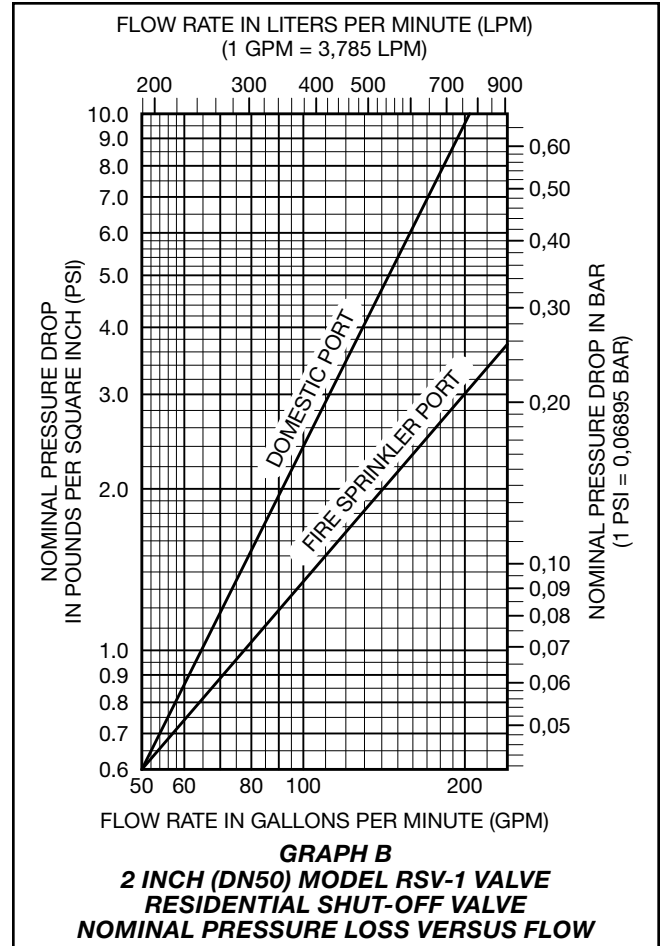
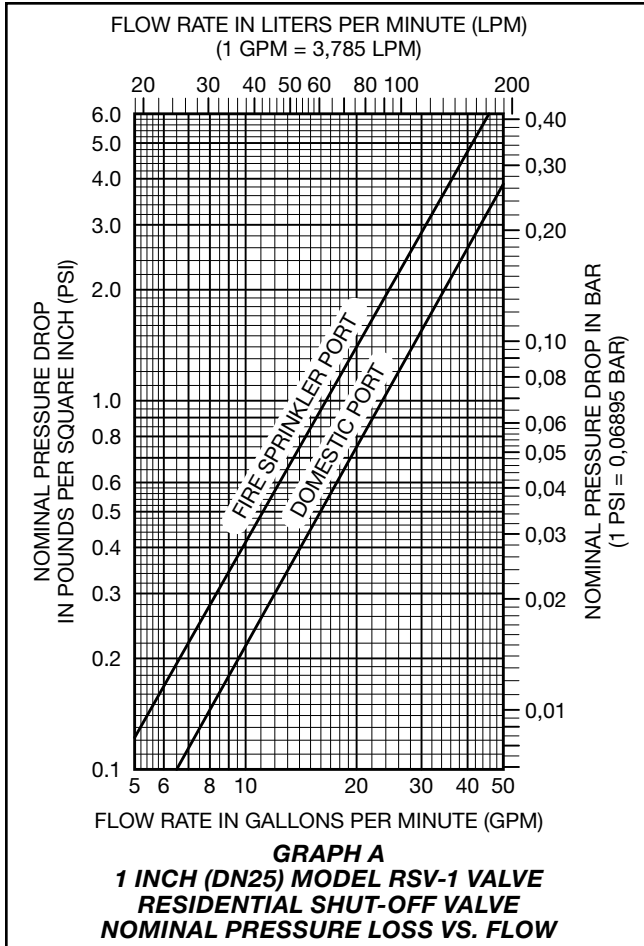

## Installation

Figure 1 illustrates a typical installation arrangement using the TYCO Model RSV-1 Residential Shut-Off Valve. The arrangement may need to be modified to meet the requirements of the authority having jurisdiction. However, the Model RSV-1 Valve must be installed in accordance with this section.

### General Instructions

A fire sprinkler water supply connection to a public water supply is usually subject to local regulations concerning metering and backflow prevention requirements. Consult with the local water authorities concerning local requirements that may apply to the arrangement of these components in the fire sprinkler system water supply.

For the 1 Inch (DN25) Valve, the maximum water supply service line is 1 Inch (DN25).

**Step 1.** Ensure that the water supply to the Model RSV-1 Valve is free of contaminants and particles of a size greater than 1/8 inch (3,2 mm).

**Step 2.** Install the Model RSV-1 Valve vertically with the Supply Port at the bottom, the Fire Sprinkler Port at the top, and the Domestic Port at the side. Ensure that the arrows cast on the Body point in the direction of flow.

A suitable clamp along the water supply riser piping is recommended to provide support for the weight of the Model RSV-1 Valve.

**Step 3.** Place a Domestic Control Valve between the Model RSV-1 Valve and the domestic system. Position the inlet to the Domestic Control Valve within 12 inches of the Domestic Port of the Model RSV-1 Valve.

**Step 4.** The Drain and Flow Test Connection (Ref. Figure 1) is recommended to be a minimum 1/2 inch (DN15) size for systems per NFPA 13D, and it must be a minimum 1 inch (DN25) size for systems per NFPA 13R.

**Step 5.** Install an Alarm Test Connection with a test orifice equal to or less than the smallest K-factor sprinkler in the system downstream of the Water-flow Detector.

**Step 6.** Apply pipe-thread sealant sparingly only to the male pipe threads that are to be assembled to the three ports of the Model RSV-1 Valve. The use of a non-hardening pipe-thread sealant such as TEFLON is recommended.

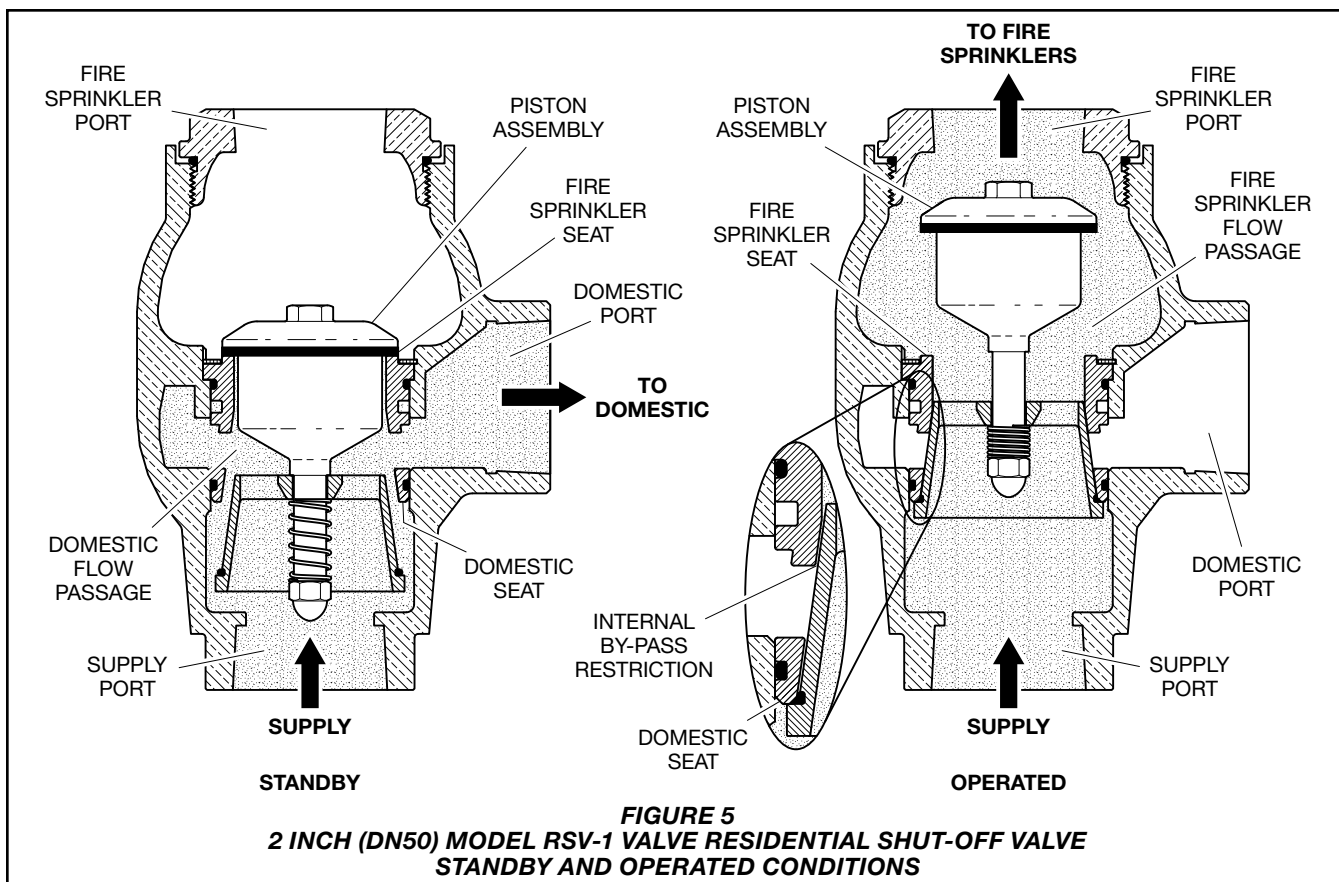
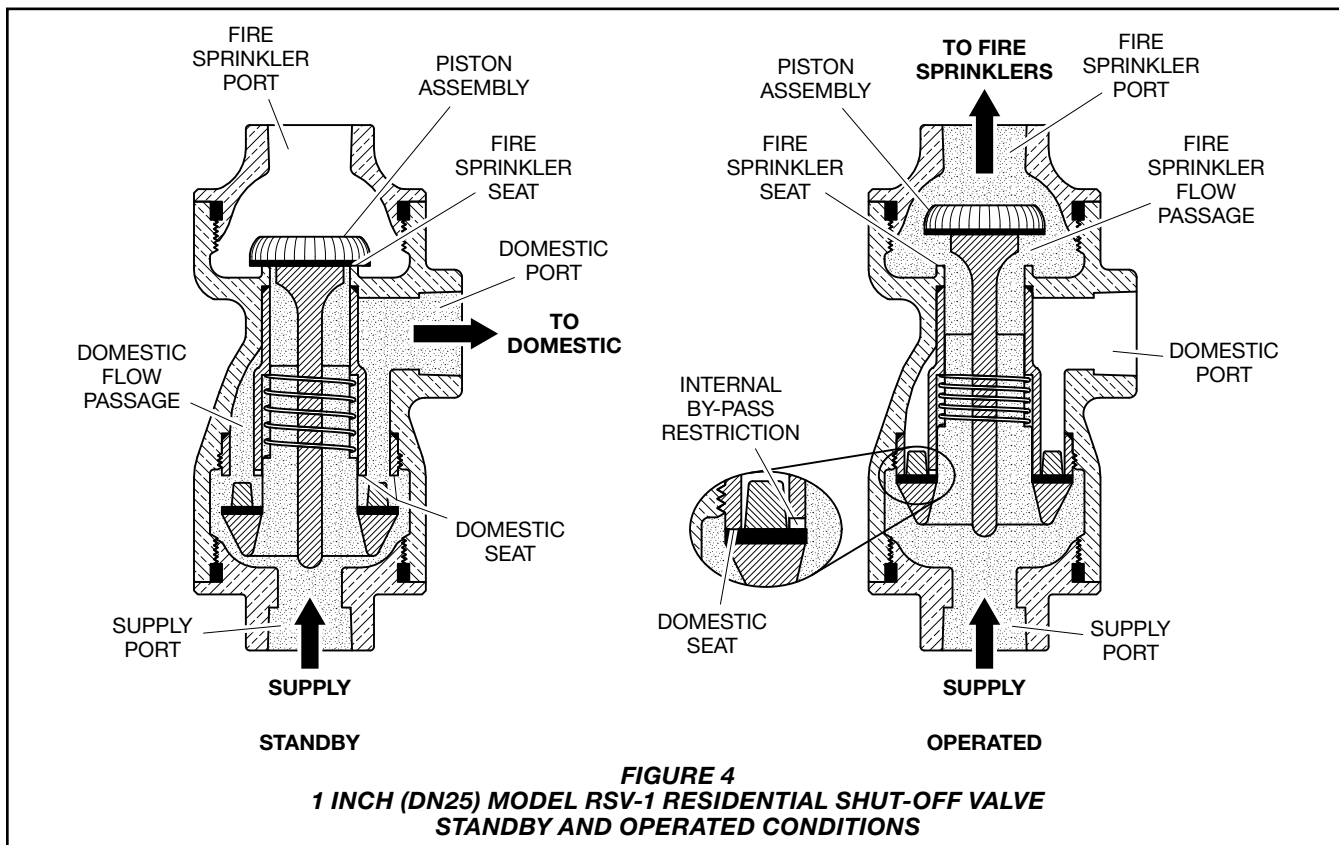

## Valve Setting Procedure

Perform steps 1 through 9 when initially filling the fire sprinkler and domestic system piping with water or after a fire sprinkler operation (Ref. Figure 1).

**Step 1.** Close the Main Control Valve.

**Step 2.** Close the Domestic Control Valve and all water outlets in the domestic piping system.

**Step 3.** In addition to the Drain and Flow Test Connection in the fire sprinkler system, close all drain valves and replace all operated sprinklers as necessary.

**Step 4.** Partially open the Main Control Valve until the sound of flowing water just begins, then leave the Main Control Valve in the partially open position.

**Step 5.** After the fire sprinkler system pressure gauge indicates approximately the same pressure as the supply pressure gauge, fully open the Main Control Valve.

**Step 6.** Open the highest elevation outlet on the domestic system.

**Step 7.** Partially open the Domestic Control Valve until the sound of flowing water begins. Allow the domestic piping to fill slowly with water.

**Step 8.** Close the highest elevation water outlet on the domestic system when unaerated water begins to flow.

**Step 9.** Completely open the Domestic Control Valve, then check that the domestic system is properly pressurized by verifying that at least three water outlets in the domestic system can flow full at the same time.

- If the water outlets flow fully, the Model RSV-1 Valve is set and ready for service. Close the water outlets on the domestic system.
- If the water outlets do not flow fully, re-close the Domestic Control Valve, wait a minimum of ten seconds, and ensure that there is no flow from the fire sprinkler system piping. Reopen the Domestic Control Valve, then recheck that the water outlets are flowing fully.

## Care and Maintenance

The following inspection procedure for the TYCO Model RSV-1 Residential Shut-Off Valve must be performed as indicated, in addition to any specific requirements of the NFPA. Any impairment must be immediately corrected.

Before closing a fire protection system control valve for inspection or maintenance work on the fire protection system that it controls, obtain permission to shut down the affected fire protection system from the proper authorities and notify all personnel who may be affected by this action.

Make no attempt to repair any Model RSV-1 Valve component in the field. The Model RSV-1 Valve is not field-repairable. If malfunction occurs, the entire unit must be replaced.

The operational test and flow test procedures result in operation of the associated alarms, as well as an interruption of the domestic water supply service. You must notify the owner, building occupants, and the fire department, central station, or other signal station to which the alarms are connected.

After placing a fire protection system in service, notify the proper authorities and advise those responsible for monitoring proprietary and/or central station alarms.

The owner is responsible for the inspection, testing, and maintenance of their fire protection system and devices in compliance with this document, as well as with the applicable standards of the National Fire Protection Association (e.g., NFPA 25), in addition to the standards of any authority having jurisdiction. Contact the installing contractor or product manufacturer regarding any questions.

Automatic sprinkler systems should be inspected, tested, and maintained by a qualified Inspection Service in accordance with local requirements and/or national codes and standards.

### Operation Test Procedure

**Step 1.** Fully open two or three water outlets in the domestic piping system.

**Step 2.** To simulate a sprinkler operation, open the Alarm Test Connection of the fire sprinkler system.

**Step 3.** Verify that any alarms are operating and that the flow from the domestic water outlets decreases to no more than a trickle.

**Step 4.** Reset the Model RSV-1 Valve in accordance with the Valve Setting Procedure described in this data sheet.

### Flow Test Procedure

**Step A.** While there is no water flowing in the domestic system, completely open the Drain and Flow Test Connection.

**Step B.** While water is flowing, record the pressure reading on the fire sprinkler system pressure gauge and then compare this reading to previous readings.

If there is a significant decrease in pressure since the last time the pressure reading was taken and this decrease is not due to a normally expected drop in the water supply pressure, an impairment may exist that should be immediately identified and corrected.

**Step C.** Close the Drain and Flow Test Connection to allow the Model RSV-1 Valve to reset automatically. Automatic resetting occurs within ten seconds.

**Step D.** After waiting ten seconds, completely open at least three water outlets in the domestic system and allow these outlets to flow simultaneously.

If the water outlets flow fully, the Model RSV-1 Valve is set and ready for service. Close the water outlets on the domestic system.

If the water outlets do not flow fully, close the Domestic Control Valve and verify that there is no flow from the fire sprinkler system piping, such as at the Inspector's Test Connection. Wait a minimum of ten seconds. Re-open the Domestic Control Valve and then recheck that the domestic system water outlets are flowing full.

## Limited Warranty

For warranty terms and conditions, visit [www.tyco-fire.com](http://www.tyco-fire.com).

## Ordering Procedure

Contact your local distributor for availability. When placing an order, indicate the full product name and Part Number (P/N).

### Valves with NPT Connections

Specify: 1 Inch NPT (DN25) Model RSV-1 Residential Shut-Off Valve, P/N 52-540-1-011

Specify: 2 Inch NPT (DN50) Model RSV-1 Residential Shut-Off Valve, P/N 52-540-1-012