

## Model QRS Electronic Accelerator (Quick Opening Device) For Dry Pipe or Preaction Systems

### IMPORTANT

Refer to Technical Data Sheet TFP2300 for warnings pertaining to regulatory and health information.

Scan the QR code or enter the URL in a web browser to access the most up-to-date electronic version of this document. Data rates may apply.



[docs.jci.com/tycofire/TFP1100](http://docs.jci.com/tycofire/TFP1100)

## General Description

The TYCO Model QRS Electronic Accelerator is a quick opening device intended to reduce the operating time of a dry pipe valve in a dry pipe system or an automatic control valve (deluge valve) in a double interlock electric/electric preaction system.

The control panel for the QRS may be used with up to four QRS switches for one to four system risers using one of the following dry pipe valves:

- TYCO 4 in. & 6 in. (DN100/150) Model DPV-1 Dry Pipe Valves
- Central 3 in. (DN80) Model AF or Central 4 in. & 6 in. (DN100/150) Model AF/AG Dry Pipe Valves
- Gem 4 in. & 6 in. (DN100/150) Model F302/F3021 Dry Pipe Valves
- Star 4 in. & 6 in. (DN100/150) Models A or A-1 Dry Pipe Valves

The control panel for the QRS may be used with one QRS switch for one system riser using the following automatic control valve (deluge valve) used in a double interlock electric/electric preaction system:

- TYCO 1-1/2 in. through 8 in. (DN40 through DN200) DV-5A Deluge Valve

The Model QRS Electronic Accelerator (see Figure 1) utilizes a unique system air pressure monitoring device (UL and C-UL Listed, as well as FM Approved, Model QRS Extinguishing System Attachment) that continuously samples air pressure twice per second. When the air pressure is determined to have a sustained drop exceeding a rate of 0.1 psi (0,007 bar) per second as verified by three consecutive samplings, the QRS signals the releasing panel (Model PFC4410-RC) via its "Panel Input" initiating zone circuit, which energizes the Solenoid Valve.

In the case of a dry pipe valve, the energized solenoid valve introduces system air pressure to the intermediate chamber of the dry pipe valve. This pressure neutralizes the differential pressure holding the dry pipe valve closed and permits it to open.

In the case of a double interlock electric/electric preaction system, the energized Solenoid Valve releases diaphragm pressure from the automatic control valve (deluge valve) to permit the automatic control valve (deluge valve) to open.

The Model QRS Electronic Accelerator automatically adjusts to both small and slow changes in system pressure, but trips when there is a steady drop in pressure (as in the case of sprinkler operation).

The QRS Electronic Accelerator features the following:

- Operation of a dry pipe or preaction valve within four seconds — independent of various combinations of system initial air pressures, system volumes, or sprinkler K-factors
- One releasing panel can control up to four dry pipe systems or one double interlock preaction system



- Built-in low pressure and high pressure alarm supervision
- Proven electric release technology as used for electrically operated deluge and preaction systems
- Battery back-up in the event of primary power failure

### NOTICE

*The Model QRS Electronic Accelerator described herein must be installed and maintained in compliance with this document, as well as with the applicable standards of the NATIONAL FIRE PROTECTION ASSOCIATION (NFPA), in addition to the standards of any other authorities having jurisdiction. Failure to do so may impair the performance of this device.*

*The owner is responsible for maintaining their fire protection system and devices in proper operating condition. Contact the installing contractor or sprinkler manufacturer with any questions.*

*The QRS uses electronic components to monitor the system air pressure. Keep all radio transmitters or RF sources at least one foot from the QRS. Failure to do so could result in an unintended operation of the dry pipe or preaction system.*

*For additional information please refer to the Potter Electric Signal Company Data Sheet #5471131 for the QRS Quick Release Switch and/or Manual #5403550 for the PFC-4410RC Releasing Panel.*

# Technical Data

## Approvals

UL Listed:

The Model QRS Electronic Accelerator is UL Listed per UL1486 for a maximum system capacity of 1690 gal (6397 L) for a single nominal 5.6 K-factor sprinkler and a maximum working water pressure of 175 psi (12,1 bar).

FM Approved:

The Model QRS Electronic Accelerator is FM Approved based on the sensitivity criteria provided in Graph A and a maximum working water pressure of 250 psi (17,2 bar).

Listings and Approvals are under the name of Potter Electric Signal Company.

## NOTICE

*Quick operation of the Electronic Accelerator does not ensure that the fire protection system will meet the water delivery time requirement of the authority having jurisdiction (following opening of the Inspector's Test Connection). The sprinkler system designer must be knowledgeable that water delivery time is primarily determined by the configuration and volume of the piping network, system air pressure at time of Accelerator trip, number and orifice size of open sprinklers, and water supply characteristics.*

*In the case of a double interlock preaction system, water delivery is also based on the electric detection system operating before the first sprinkler activates.*

## Dry Pipe Valve Compatibility

The Model QRS Electronic Accelerator is UL Listed and FM Approved for use with the following dry pipe valves:

- 4 in. and 6 in. (DN 100/150) TYCO DPV-1 3 in. (DN80) Central AF
- 4 in. and 6 in. (DN100/150) Central AF/AG
- 4 in. and 6 in. (DN100/150) Gem F302/F3021
- 4 in. and 6 in. (DN100/150) Star Model A
- 4 in. and 6 in. (DN100/150) Star Model A-1

## Precision System Compatibility

The Model QRS Electronic Accelerator is UL Listed and FM Approved for use with the 1-1/2 in. through 8 in. (DN40 through DN200) DV-5A Double Interlock Electric/Electric Precision System. Refer to Technical Data Sheet TFP1466.

## Maximum Working Air Pressure

70 psi (4,8 bar)

## Pressure Decay For Trip Rating

0.1 psi/sec. (0,007 bar/s)

## High/Low Pressure Settings

See Table A.

## Environmental Specifications

The QRS Quick Release Switch is for indoor use only (NEMA 1/IP50).

## Battery Back-Up

Battery back-up for dry pipe systems is provided by two BT-120 (12 AH) batteries or two (optional) BT-180 (18 AH) batteries. See the Ordering Procedure section for details.

The two BT-120 batteries provide:

- 40 hours in standby with four QRS switches
- With four QRS switches connected, with one in alarm and the solenoid activated continuously, the batteries will provide 12 additional hours of standby
- With three QRS switches connected, with one in alarm and the solenoid activated continuously, the batteries will provide 13 additional hours of standby
- With two QRS switches connected, with one in alarm and the solenoid activated continuously, the batteries will provide 14 additional hours of standby.

For double interlock preaction systems, battery calculations must be performed by the system designer to determine adequacy of the two batteries to meet the requirements of the authority having jurisdiction.

A battery calculation form can be accessed on the Potter website at <http://www.pottersignal.com/fire/batterytools/php>

# Installation

The TYCO Model QRS Electronic Accelerator must be installed in accordance with this section.

**Step 1.** The QRS Electronic Accelerator Riser Components (P/N 52-312-2001) must be installed per Figure 2 or 8 as applicable. The DV-5A Double Interlock Precision Trim with Electric/Electric Actuation and Model QRS Electronic Accelerator must be installed per Figure 3A or 3B. The solenoid valve must be installed with its flow direction arrow as indicated. Apply the pipe thread sealant sparingly to male threads only.

**Step 2.** The releasing panel is to be located in a dry and protected area; however, it should be located in close proximity to the valve riser(s). In the case of one panel being used for multiple dry pipe valve risers, it is recommended that a single panel only be used when the multiple risers are adja-

cent to each other. Otherwise, difficulty may be encountered when performing the resetting procedure.

**Step 3.** The QRS switch, solenoid valve and releasing panel must be wired per Figure 5 or 6, as applicable. All electrical connections are to meet the requirements of NFPA 72.

## NOTICE

*Figure 5 provides the wiring connections for dry pipe systems using the PFC-4410RC Standard Program #14. Figure 6 provides the wiring connections for a double interlock electric/electric preaction system using the PFC-4410RC Standard Program #13.*

*In the case of Figure 5, the EOLR for the supervisory circuit is located in the last QRS switch. In the case of Figure 6, the EOLR for the supervisory zone is located at the QRS switch and the orange and yellow wires are not used. Any tamper switches for system shut off valves required for double interlock preaction systems should be connected to Zone 3 of the PFC-4410RC releasing panel which is programmed as a Tamper Zone. Refer to PFC-4410RC Manual #5403550.*

All QRS switch wiring must be terminated (landed) while the PFC-4410RC is de-energized. Failure to do so may result in unseen damage to the QRS switch, rendering it inoperable.

To de-energize the PFC-4410RC, disconnect the stand-by batteries, then disconnect the A/C input. Reverse this process to re-energize the panel.

For additional PFC-4410RC Releasing Panel information (for example, power and battery connections, programming, and basic operation) refer to the Potter Electric Signal Company Manual #5403550.

**Step 4.** As a function of the nominal air pressure to be maintained in the sprinkler system, set the 10 position, high/low level, rotary switch setting of the QRS switch using the information provided in Table A as well as inside the cover of the QRS switch.

**Step 5.** To complete the installation, the cover of the QRS switch must be securely fastened to the base to ensure metal-to-metal contact, and the PFC-4410RC Releasing Panel must be programmed using Standard Program #13 or #14, as applicable. Programming instructions are provided in Potter Electric Signal Company Manual #5403550.

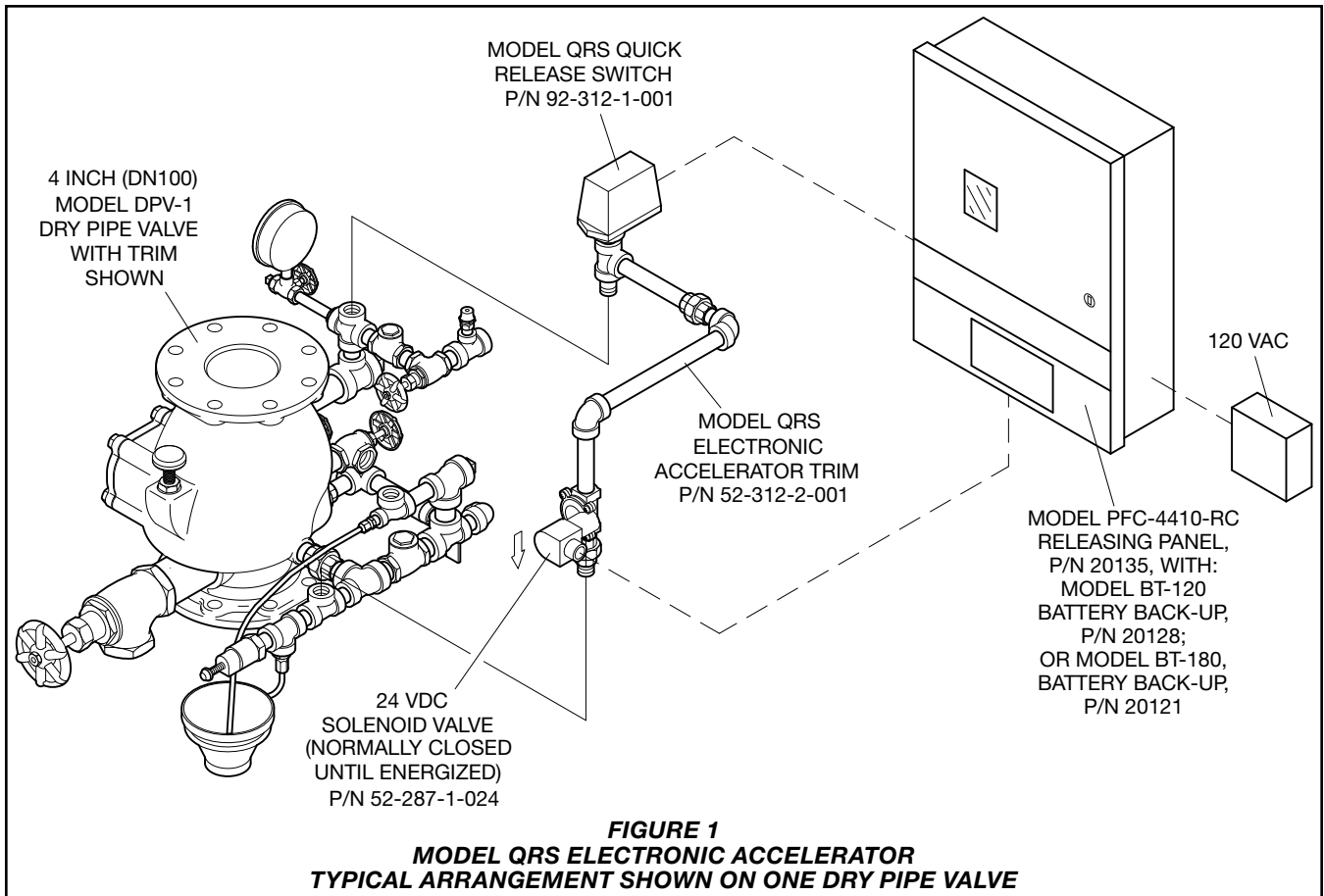

Switch Setting	Low Air Threshold psi (bar)	Nominal Pressure psi (bar)	High Air Threshold psi (bar)
0	7 (0,48)	10 (0,69)	15 (1,04)
1	7 (0,48)	15 (1,04)	20 (1,38)
2	15 (1,04)	20 (1,38)	25 (1,72)
3	15 (1,04)	25 (1,72)	30 (2,07)
4	20 (1,38)	30 (2,07)	35 (2,41)
5	25 (1,72)	35 (2,41)	40 (2,76)
6	30 (2,07)	40 (2,76)	45 (3,10)
7	35 (2,41)	45 (3,10)	50 (3,45)
8	45 (3,10)	55 (3,79)	60 (4,14)
9	55 (3,79)	65 (4,48)	70 (4,83)

**TABLE A**  
**HIGH/LOW PRESSURE SETTINGS FOR THE**  
**MODEL QRS QUICK RELEASE SWITCH**

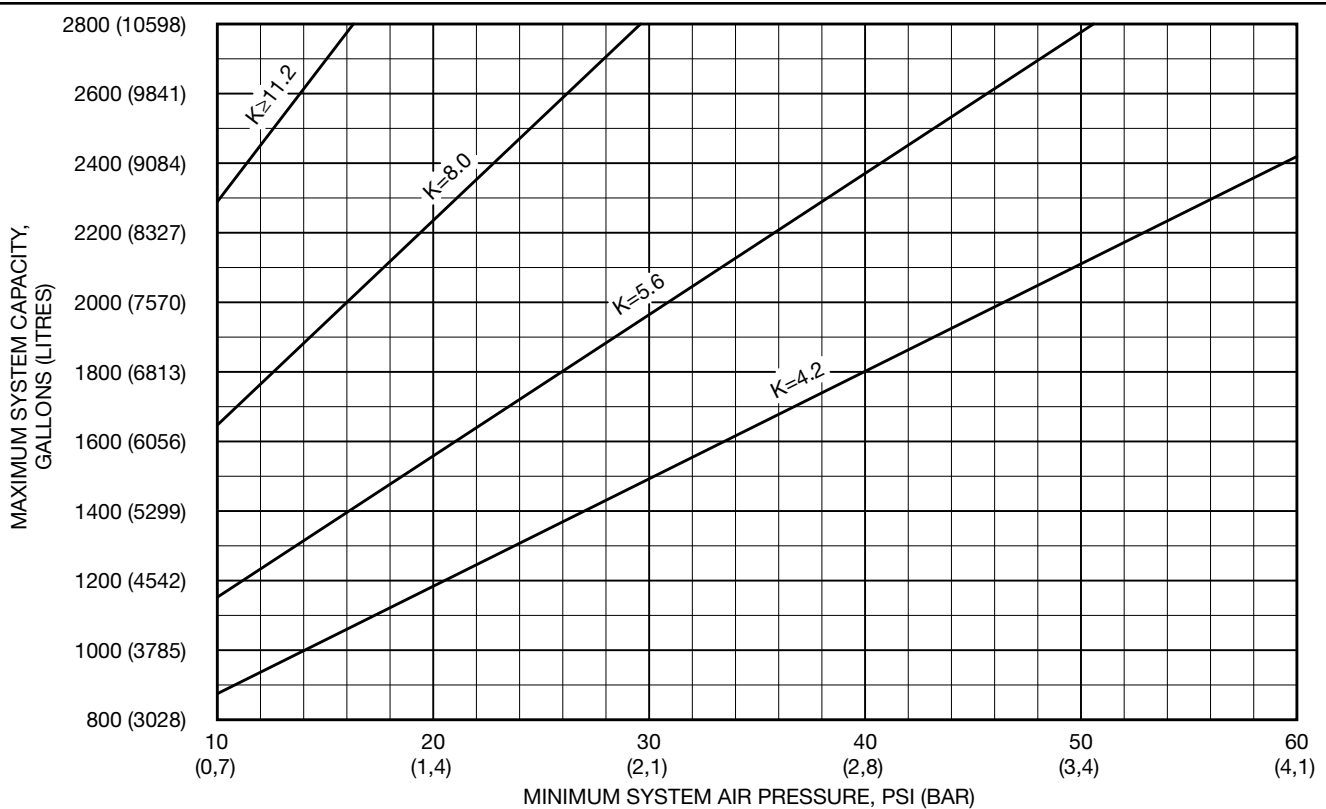

**Notes:**

1. Quick operation of the electronic accelerator does not ensure that the fire protection system will meet the water delivery time requirement of the authority having jurisdiction (following opening of the inspector's test connection). The sprinkler system designer has to be aware that water delivery time is primarily determined by the configuration and volume of the piping network, system air pressure at time of accelerator trip, number and orifice size of open sprinklers, and water supply characteristics.
2. The sensitivity criteria for the Model QRS Electronic Accelerator is a function of its pressure decay for trip rating of 0.1 psi (0,007 bar) per second, as well as the system volume, the K-factor of the sprinklers being utilized, and the minimum initial air pressure. The larger the system volume combined with smaller sprinkler K-factor or lower initial air pressure results in a slower air decay rate upon the first sprinkler operation. Conversely, a smaller system volume combined with a larger sprinkler K-factor or higher initial air pressure results in a faster air decay rate.
3. When the sprinkler system has been designed within the criteria provided by Graph A, operation of the QRS switch and subsequent operation of the associated dry pipe or preaction valve can be expected within four seconds. In the case of the double interlock preaction system, operation is based on the electric detection system operating before a first sprinkler operation.
4. The minimum system air pressure must be the greater of that required for the dry pipe / preaction valve as a function of the maximum expected water supply pressure or per Graph A when using the QRS switch.
5. When multiple sprinkler operations are being considered as in the case of using a dry system water delivery design per the 2002 edition of NFPA 13, Section 11.2.3.9, use the "11.2 K-factor and larger" curve as referenced in Example 3.

**Examples:**

1. Assuming a system volume of 1500 gal (5680 L) and the use of sprinklers having a K-factor of 5.6, the minimum system air pressure must be 18.5 psi (1,3 bar).
2. Assuming a system volume of 2000 gal (7570 L) and the use of sprinklers having a K-factor of 8.0, the minimum system air pressure must be 16.0 psi (1,1 bar).
3. Assuming the use of a dry system water delivery design per the 2007 edition of NFPA 13, Section 7.2.3.6, where in the operation of two 5.6 K-factor sprinklers might be anticipated (and the effective K-factor is then 11.2), the "11.2 K-factor and larger" curve can be utilized. Consequently, assuming a system volume of 2400 gal (9084 L), the minimum system air pressure must be 11.5 psi (0,8 bar).

**GRAPH A**  
**MODEL QRS ELECTRONIC ACCELERATOR**  
**SENSITIVITY CRITERIA BASED ON FM APPROVAL**

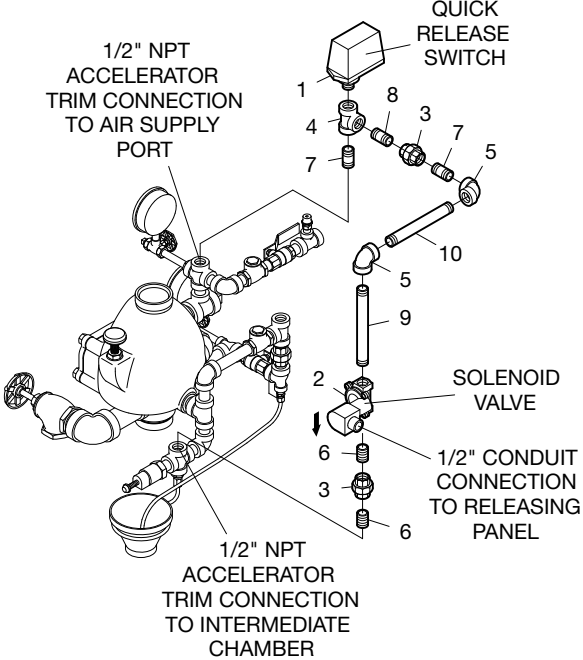

**2-1/2 or 3 INCH (DN65 or DN80)**

NO	DESCRIPTION	QTY	P/N
1	Quick Release Switch, Model QRS	1	92-312-1-001
2	Solenoid Valve	1	52-287-1-024
3	1/2" Union	2	CH
4	1/2" Tee	1	CH
5	1/2" 90° Elbow	2	CH
6	1/2" x Close Nipple	2	CH
7	1/2" x 1-1/2" Nipple	2	CH
8	1/2" x 1-1/2" Nipple for 2-12 and 3 Inch Valves	1	CH
	1/2" x 5-1/2" Nipple for 4 and 6 Inch Valves	1	CH
9	1/2" x 6-1/2" Nipple for 2-12 and 3 Inch Valves	1	CH
	1/2" x 4-1/2" Nipple for 4 Inch Valves	1	CH
	1/2" x 7" Nipple for 6 Inch Valves	1	CH
10	1/2" x 7" Nipple for 2-12 and 3 Inch Valves	1	CH
	1/2" x 9-1/2" Nipple for 4 Inch Valves	1	CH
	1/2" x 8-1/2" Nipple for 6 Inch Valves	1	CH

CH: Common Hardware

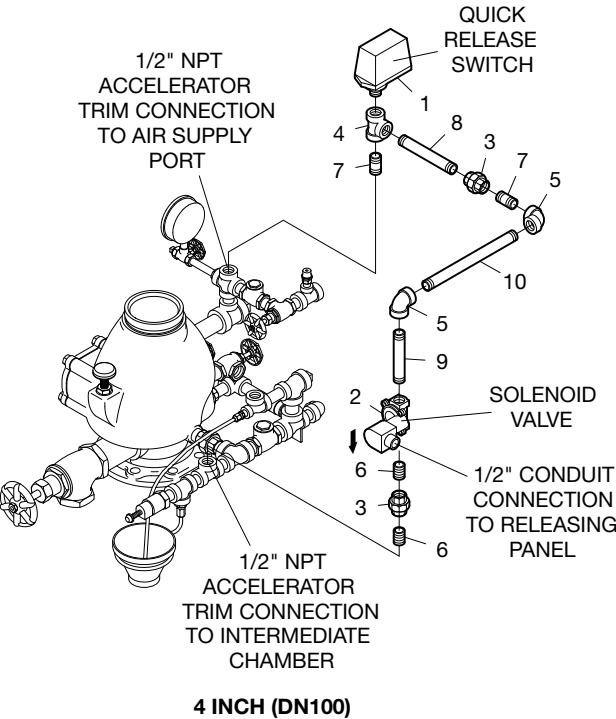

**4 INCH (DN100)**

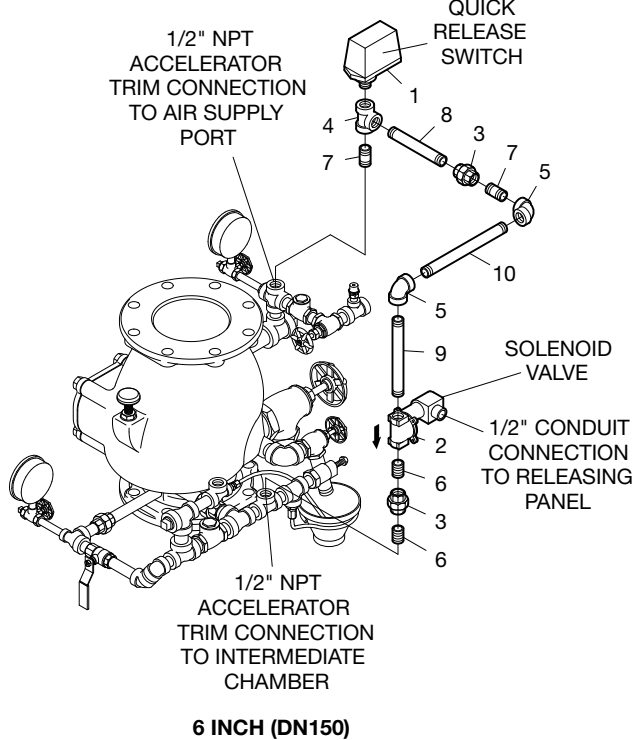

**6 INCH (DN150)**

**FIGURE 2**  
**MODEL QRS ELECTRONIC ACCELERATOR RISER COMPONENTS**  
**INSTALLATION DIAGRAM FOR THE**  
**4 AND 6 INCH MODEL DPV-1 DRY PIPE VALVES (P/N 52-312-2-001)**

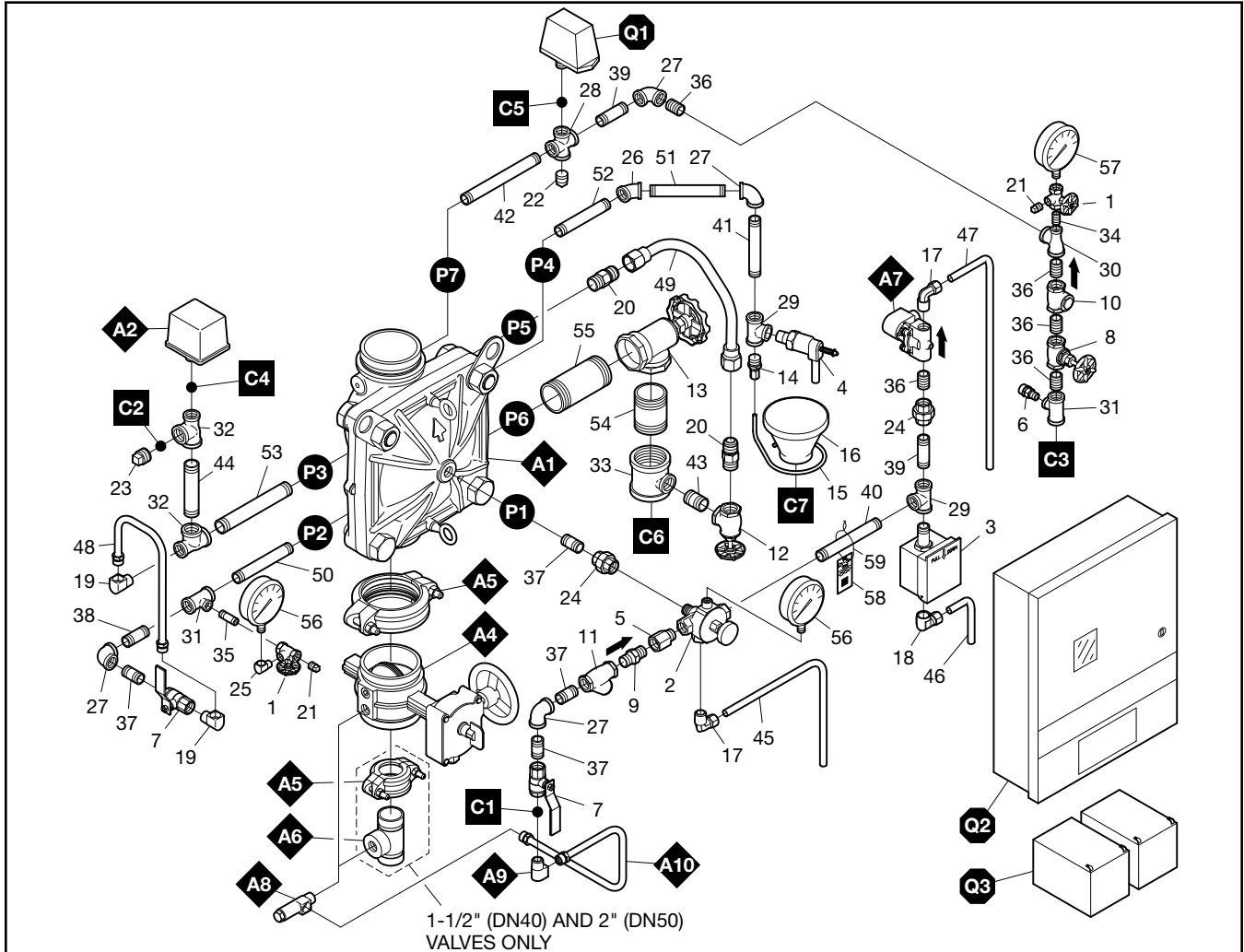

**Notes:**

- Port Connections P1 through P7 are described in Technical Data Sheet TFP1466, Figure 2.
- External Trim Connections C1 through C8 are described in Figure 3B.
- When ordering the pre-assembled DV-5A Valve with Galvanized Valve Trim or the pre-assembled DV-5A Valve with Galvanized Valve Trim and Butterfly Valve, items A1 through A10 are provided as applicably related to valve size, refer to Technical Data Sheet TFP1466, and item A7 is provided as P/N 52-287-1-124 described in Technical Data Sheet TFP2180.
- When ordering the DV-5A Trim separately from the DV-5A Valve, items A1 through A10 are separately ordered, as applicably related to valve size. Water Pressure Gauges for the EMEA valve trim are also separately ordered. Refer to Technical Data Sheet TFP1466.

ITEM	QTY	DESCRIPTION	CH	1-1/2 IN. (DN40)	2 IN. (DN50)	3 IN. (DN80)	4 IN. (DN100)	6 IN. (DN150)	8 IN. (DN200)
1	2	1/4" GAUGE TEST VALVE		460051003	460051003	460051003	460051003	460051003	460051003
2	1	MRA-1 MANUAL RESET ACTUATOR		545001000	545001000	545001000	545001000	545001000	545001000
3	1	MC-2 MANUAL CONTROL STATION		545002000	545002000	545002000	545002000	545002000	545002000
4	1	AD-3 AUTOMATIC DRAIN VALVE		547932004	547932004	547932004	547932004	547932004	547932004
5	1	PRIMING SUPPLY RESTRICTION		545100051	545100051	545100051	545100051	545100051	545100051
6	1	1/4" PRESSURE RELIEF VALVE		923431020	923431020	923431020	923431020	923431020	923431020
7	2	1/2" BALL VALVE		460501004	460501004	460501004	460501004	460501004	460501004
8	1	1/2" GLOBE VALVE		460471005	460471005	460471005	460471005	460471005	460471005
9	1	1/2" SPRING LOADED CHECK VALVE		923221003	923221003	923221003	923221003	923221003	923221003
10	1	1/2" SWING CHECK VALVE		460491007	460491007	460491007	460491007	460491007	460491007
11	1	1/2" Y-STRAINER		523531006	523531006	523531006	523531006	523531006	523531006
12	1	3/4" ANGLE VALVE		460481010	460481010	460481010	460481010	460481010	460481010
13	1	ANGLE VALVE		460481010	460481010	460481011	460481012	460481012	460481012
14	1	DRIP FUNNEL BRACKET CONNECTOR		922111005	922111005	922111005	922111005	922111005	922111005
15	1	DRIP FUNNEL BRACKET		922111003	922111003	922111003	922111003	922111003	922111003
16	1	DRIP FUNNEL		923431007	923431007	923431007	923431007	923431007	923431007
17	2	COMP. FITTING 90° 1/2" MNPT x 1/2" OD TUBE		1001253-01	1001253-01	1001253-01	1001253-01	1001253-01	1001253-01
18	1	COMP. FITTING 90° 1/2" FNPT x 1/2" OD TUBE		1001420-01	1001420-01	1001420-01	1001420-01	1001420-01	1001420-01

**FIGURE 3A (PART 1 OF 2)**  
**DV-5A VALVE - DOUBLE INTERLOCK PREACTION ELECTRIC/ELECTRIC ACTUATION TRIM**  
**WITH MODEL QRS ELECTRONIC ACCELERATOR OPTIONAL COMPONENTS**  
**EXPLODED VIEW**

ITEM	QTY	DESCRIPTION	CH	1-1/2 IN. (DN40)	2 IN. (DN50)	3 IN. (DN80)	4 IN. (DN100)	6 IN. (DN150)	8 IN. (DN200)
19	2	FLARE FITTING 90° 1/2" NPT x 1/2" TUBE		545100062	545100062	545100062	545100062	545100062	545100062
20	2	FLARE FITTING 3/4" NPT x 3/4" TUBE		545100063	545100063	545100063	545100063	545100063	545100063
21	2	PIPE PLUG	✓	1/4"	1/4"	1/4"	1/4"	1/4"	1/4"
22	1	PIPE PLUG	✓	1/2"	1/2"	1/2"	1/2"	1/2"	1/2"
23	1	PIPE PLUG	✓	3/4"	3/4"	3/4"	3/4"	3/4"	3/4"
24	2	UNION	✓	1/2"	1/2"	1/2"	1/2"	1/2"	1/2"
25	1	STREET ELBOW	✓	1/4" x 90°	1/4" x 90°	1/4" x 90°	1/4" x 90°	1/4" x 90°	1/4" x 90°
26	1	ELBOW	✓	1/2" x 45°	1/2" x 45°	1/2" x 45°	1/2" x 45°	1/2" x 45°	1/2" x 45°
27	4	ELBOW	✓	1/2" x 90°	1/2" x 90°	1/2" x 90°	1/2" x 90°	1/2" x 90°	1/2" x 90°
28	1	CROSS	✓	1/2"	1/2"	1/2"	1/2"	1/2"	1/2"
29	2	TEE	✓	1/2"	1/2"	1/2"	1/2"	1/2"	1/2"
30	1	REDUCING TEE	✓	1/2" x 1/4" x 1/2"	1/2" x 1/4" x 1/2"	1/2" x 1/4" x 1/2"	1/2" x 1/4" x 1/2"	1/2" x 1/4" x 1/2"	1/2" x 1/4" x 1/2"
31	2	REDUCING TEE	✓	1/2" x 1/2" x 1/4"	1/2" x 1/2" x 1/4"	1/2" x 1/2" x 1/4"	1/2" x 1/2" x 1/4"	1/2" x 1/2" x 1/4"	1/2" x 1/2" x 1/4"
32	2	REDUCING TEE	✓	3/4" x 1/2" x 3/4"	3/4" x 1/2" x 3/4"	3/4" x 1/2" x 3/4"	3/4" x 1/2" x 3/4"	3/4" x 1/2" x 3/4"	3/4" x 1/2" x 3/4"
33	1	REDUCING TEE	✓	3/4" x 3/4" x 3/4"	3/4" x 3/4" x 3/4"	1-1/4" x 1-1/4" x 3/4"	2" x 2" x 3/4"	2" x 2" x 3/4"	2" x 2" x 3/4"
34	1	PIPE NIPPLE	✓	1/4" x CLOSE	1/4" x CLOSE	1/4" x CLOSE	1/4" x CLOSE	1/4" x CLOSE	1/4" x CLOSE
35	1	PIPE NIPPLE	✓	1/4" x 1-1/2"	1/4" x 1-1/2"	1/4" x 1-1/2"	1/4" x 1-1/2"	1/4" x 1-1/2"	1/4" x 1-1/2"
36	5	PIPE NIPPLE	✓	1/2" x CLOSE	1/2" x CLOSE	1/2" x CLOSE	1/2" x CLOSE	1/2" x CLOSE	1/2" x CLOSE
37	4	PIPE NIPPLE	✓	1/2" x 1-1/2"	1/2" x 1-1/2"	1/2" x 1-1/2"	1/2" x 1-1/2"	1/2" x 1-1/2"	1/2" x 1-1/2"
38	1	PIPE NIPPLE	✓	1/2" x 2"	1/2" x 2"	1/2" x 2"	1/2" x 2"	1/2" x 2"	1/2" x 2"
39	2	PIPE NIPPLE	✓	1/2" x 2-1/2"	1/2" x 2-1/2"	1/2" x 2-1/2"	1/2" x 2-1/2"	1/2" x 2-1/2"	1/2" x 2-1/2"
40	1	PIPE NIPPLE	✓	1/2" x 4-1/2"	1/2" x 4-1/2"	1/2" x 4-1/2"	1/2" x 4-1/2"	1/2" x 4-1/2"	1/2" x 4-1/2"
41	1	PIPE NIPPLE	✓	1/2" x 5"	1/2" x 5"	1/2" x 5"	1/2" x 5"	1/2" x 5"	1/2" x 5"
42	1	PIPE NIPPLE	✓	1/2" x 8-1/2"	1/2" x 8-1/2"	1/2" x 8-1/2"	1/2" x 8-1/2"	1/2" x 8-1/2"	1/2" x 8-1/2"
43	1	PIPE NIPPLE	✓	3/4" x 1-1/2"	3/4" x 1-1/2"	3/4" x 1-1/2"	3/4" x 1-1/2"	3/4" x 1-1/2"	3/4" x 1-1/2"
44	1	PIPE NIPPLE	✓	3/4" x 4-1/2"	3/4" x 4-1/2"	3/4" x 4-1/2"	3/4" x 4-1/2"	3/4" x 4-1/2"	3/4" x 4-1/2"
45	1	TUBING, MRA-1 DRAIN		545100065	545100065	545100066	535002140	535002160	535002180
46	1	TUBING, MC-2 DRAIN		535000220	535000220	535000230	535000240	535000260	535000280
47	1	TUBING, SOLENOID DRAIN		535001020	535001020	535000630	535000640	535000660	535000680
48	1	TUBING ASSY, ALARM TEST INTERCONNECT		535000320	535000320	535000330	535000340	535000360	535000380
49	1	TUBING ASSY, SYSTEM DRAIN		535000420	535000420	535000430	535000440	535000460	535000480
50	1	PIPE NIPPLE	✓	1/2" x 3-1/2"	1/2" x 3-1/2"	1/2" x 4-1/2"	1/2" x 5-1/2"	1/2" x 5-1/2"	1/2" x 6-3/4"
51	1	PIPE NIPPLE	✓	1/2" x 5"	1/2" x 5"	1/2" x 5-1/2"	1/2" x 5-1/2"	1/2" x 5-1/2"	1/2" x 6-1/2"
52	1	PIPE NIPPLE	✓	1/2" x 5"	1/2" x 5"	1/2" x 4-1/2"	1/2" x 5"	1/2" x 4-1/2"	1/2" x 4-1/2"
53	1	PIPE NIPPLE	✓	3/4" x 5"	3/4" x 5"	3/4" x 6"	3/4" x 7"	3/4" x 9"	3/4" x 11-1/2"
54	1	PIPE NIPPLE	✓	3/4" x 4-1/2"	3/4" x 4-1/2"	1-1/4" x 3-1/4"	2" x 3"	2" x 3"	2" x 3"
55	1	PIPE NIPPLE	✓	3/4" x 6-1/2"	3/4" x 6-1/2"	1-1/4" x 5-1/2"	2" x 5"	2" x 6"	2" x 8"
56	2	WATER PRESSURE GAUGE, 300 PSI / 2000 kPa (AMER/APAC)		923431005	923431005	923431005	923431005	923431005	923431005
	2	WATER PRESSURE GAUGE, 20 bar / 2000 kPa (EMEA)		025500013	025500013	025500013	025500013	025500013	025500013
57	1	AIR PRESSURE GAUGE, 80 PSI / 550 kPa RETARDED TO 250 PSI / 1750 kPa		923431012	923431012	923431012	923431012	923431012	923431012
58	1	LABEL		545003005	545003005	545003005	545003005	545003005	545003005
59	1	LABEL WIRE		—	—	—	—	—	—
A1	1	DV-5a VALVE		REFER TO TFP1466, TABLE E FOR DV-5a PART NUMBERS.					
A2	1	WATERFLOW PRESSURE ALARM SWITCH, PS10-2 (AMER/APAC)		25710	25710	25710	25710	25710	25710
	1	WATERFLOW PRESSURE ALARM SWITCH, PS10-1 (EMEA)		0260	0260	0260	0260	0260	0260
A3	1	Not Used		—	—	—	—	—	—
A4	1	BUTTERFLY VALVE, G x G		51024A	51021A	—	—	—	—
	1	BFV-300 BUTTERFLY VALVE, G x G		—	—	59300G030WS	59300G040WS	59300G060WS	59300G080WS
A5	2	FIGURE 577 RIGID GROOVED COUPLING		57715ACP	57720ACP	—	—	—	—
	1	FIGURE 577 RIGID GROOVED COUPLING		—	—	57730ACP	57740ACP	57760ACP	57780ACP
A6	1	GROOVE x THREADED OUTLET WELDED TEE		545004000	545004001	—	—	—	—
A7	1	SOLENOID VALVE NORMALLY CLOSED (SEPARATELY ORDERED)		REFER TO TFP2180	REFER TO TFP2180	REFER TO TFP2180	REFER TO TFP2180	REFER TO TFP2180	REFER TO TFP2180
A8	1	FLARE FITTING 90°		545100100	545100100	545100099	545100100	545100100	545100100
A9	1	FLARE FITTING 90° 1/2" NPT x 1/2" TUBE		545100062	545100062	545100062	545100062	545100062	545100062
A10	1	TUBING ASSY, DIAPHRAGM CHAMBER SUPPLY		540000015	540000020	540000030	540000040	540000060	540000080
Q1	1	MODEL QRS QUICK RELEASE SWITCH		923121001	923121001	923121001	923121001	923121001	923121001
Q2	1	RELEASING PANEL, MODEL PFC-4410RC		20135	20135	20135	20135	20135	20135
Q3	2	BATTERY BACK-UP, MODEL BT-120		20128	20128	20128	20128	20128	20128

**Notes:**  
• CH - Common Hardware

**FIGURE 3A (PART 2 OF 2)**  
**DV-5a VALVE - DOUBLE INTERLOCK PREACTION ELECTRIC/ELECTRIC ACTUATION TRIM**  
**WITH MODEL QRS ELECTRONIC ACCELERATOR OPTIONAL COMPONENTS**  
**EXPLODED VIEW**

Item	Description	Item	Description	External Trim Connections	
A	DV-5A Valve	M	Manual Control Station	C1	Diaphragm Supply Connection
B	System Main Control Valve	N	Manual Reset Actuator	C2	Water Motor Alarm Connection
C	Waterflow Pressure Switch	P	Diaphragm Supply Valve	C3	Air Supply Connection
D	Main Drain Valve	Q	Diaphragm Supply Strainer	C4	Waterflow Pressure Alarm Switch
E	System Drain Valve	R	Water Supply Shut-Off	C5	Connection
F	Automatic Drain Valve	S	Air Supply Valve	C6	Low Air Pressure Switch
G	Alarm Test Valve	T	Air Pressure Relief Valve	C7	Connection
H	Alarm Control Valve (Optional)	U	Not Used	C8	Main Drain Connection
J	Water Supply Gauge	V	Solenoid Valve		Drip Funnel Drain Connection
K	Diaphragm Gauge	W	Not Used		Fire Detection System
L	System Gauge	X	System Shut-Off Valve		Connection

QRS Equipment	
Q1	QRS Switch
Q2	Releasing Panel
Q3	Battery Back-Up

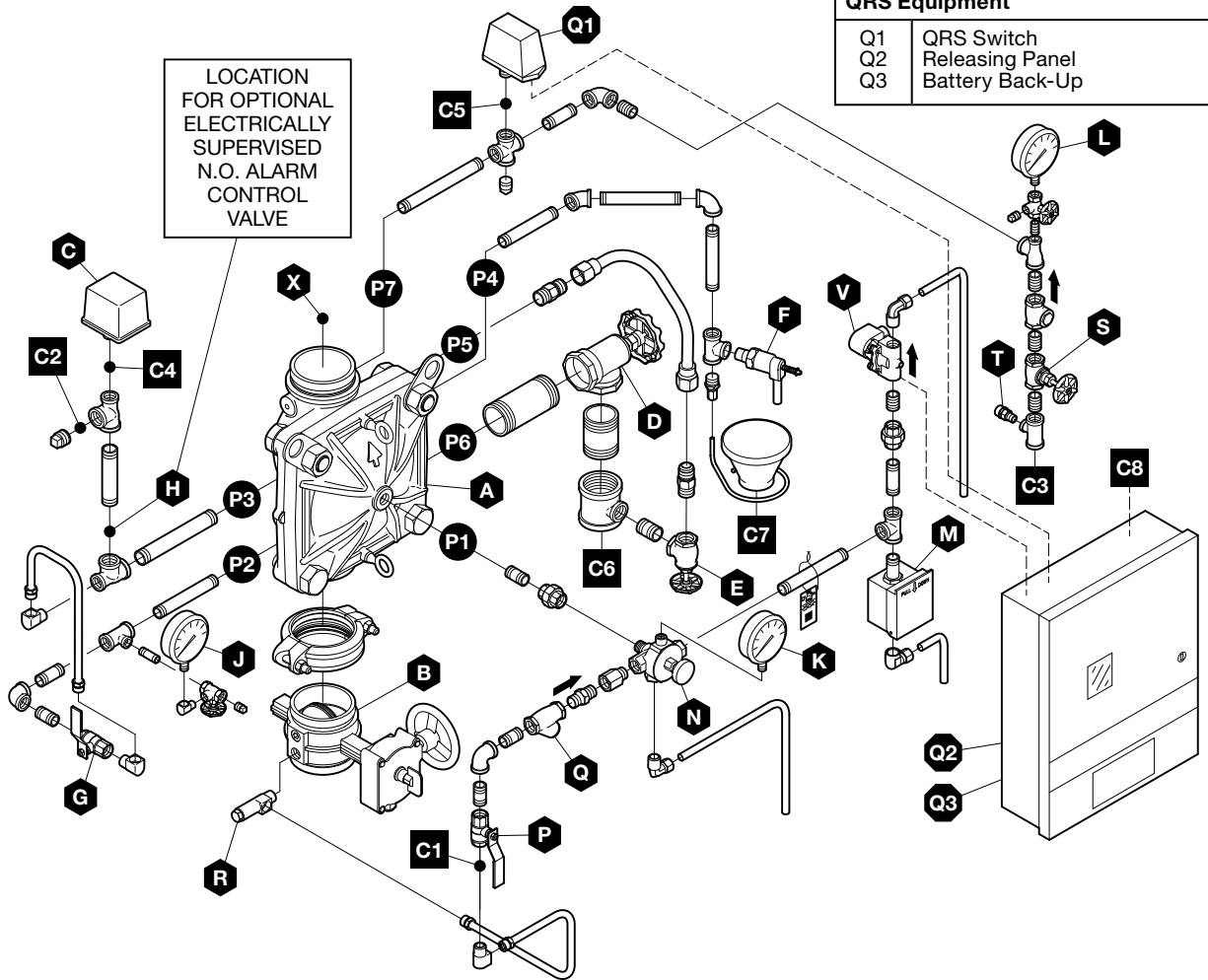

**Notes:**  
 • Port Connections P1 through P7 are described in Technical Data Sheet TFP1466, Figure 2.

**FIGURE 3B**  
**DV-5A VALVE - DOUBLE INTERLOCK PREACTION ELECTRIC/ELECTRIC ACTUATION TRIM**  
**WITH MODEL QRS ELECTRONIC ACCELERATOR OPTIONAL COMPONENTS**  
**OPERATIONAL COMPONENTS**



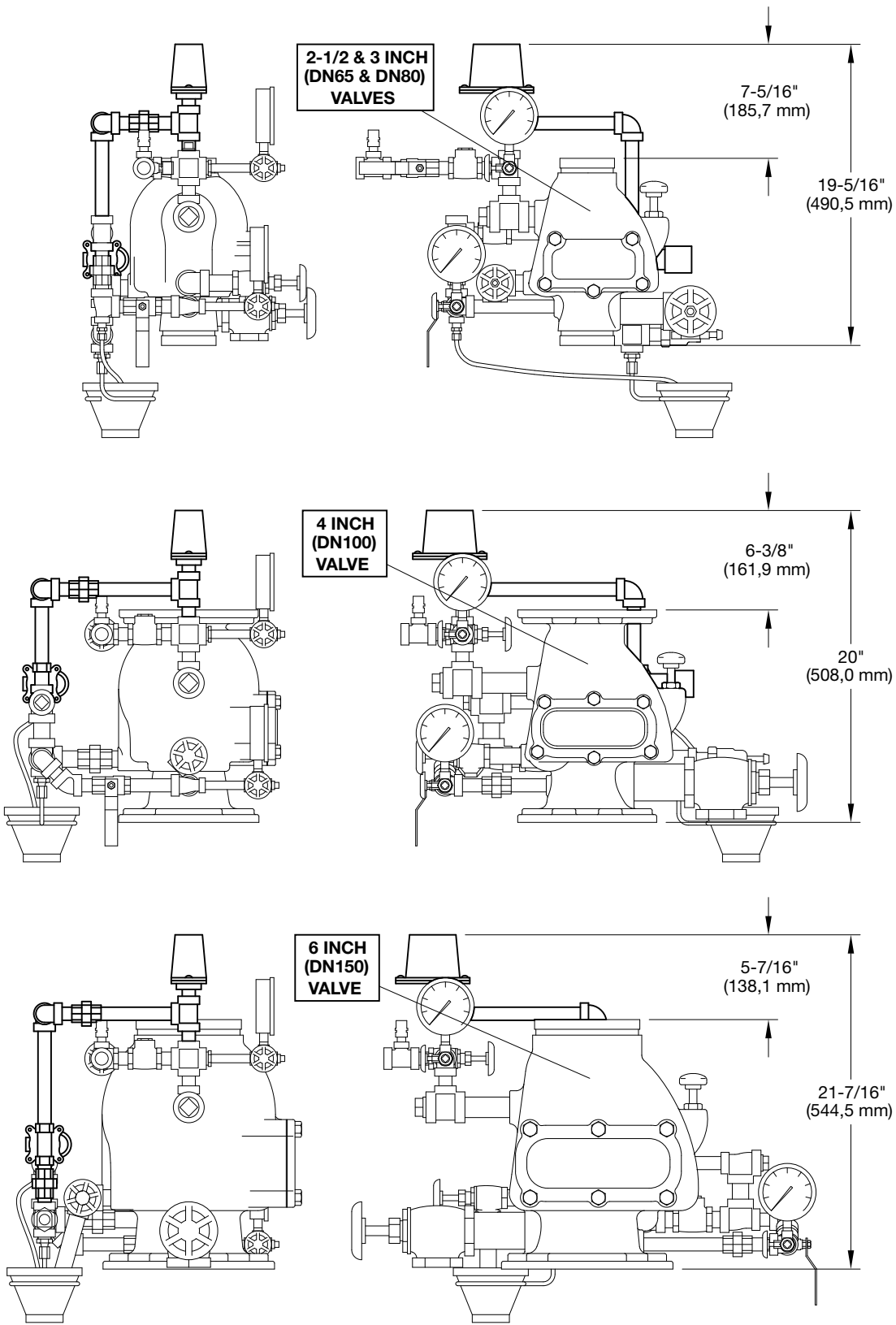
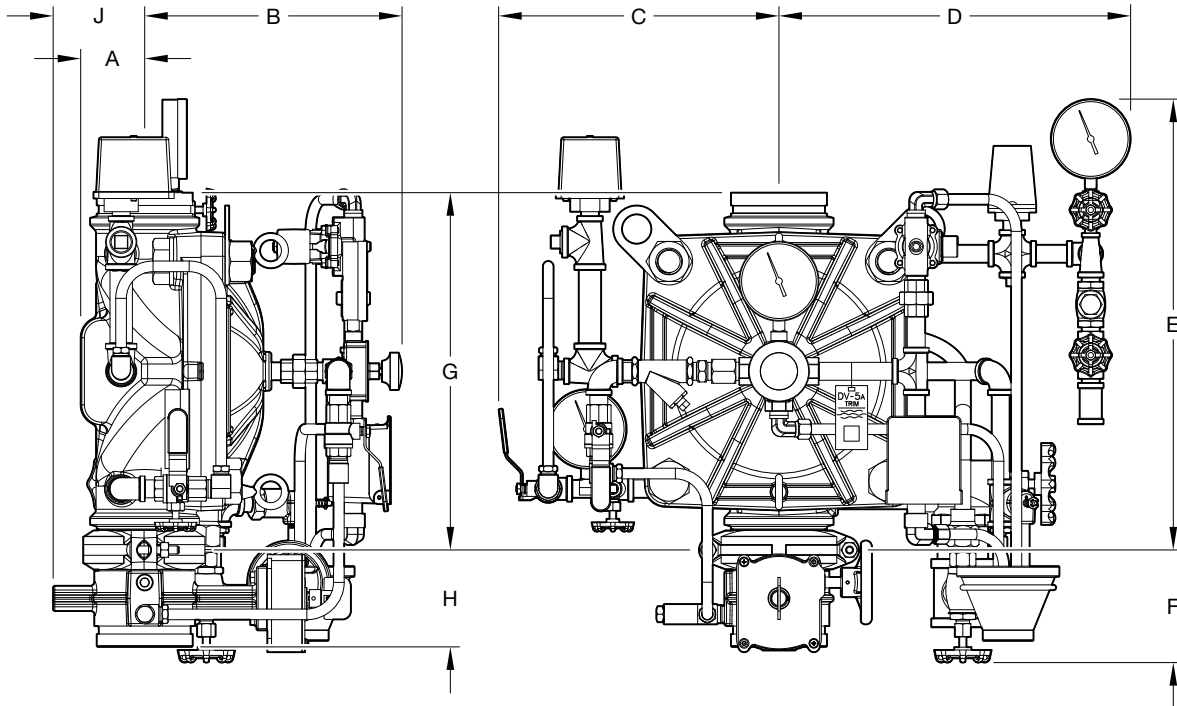

**FIGURE 4A**  
**MODEL DPV-1 DRY PIPE VALVE**  
**INSTALLATION DIMENSIONS, PRE-TRIMMED VALVE**

Nominal Valve Size ANSI Inches (DN)	Inches (mm)								
	A	B	C	D	E	F	G	H	J
1-1/2 (40)	2.8 (71)	9.7 (246)	10.4 (264)	15.7 (399)	16.2 (412)	7.3 (185)	10.2 (259)	8.0 (203)	1.2 (31)
2 (50)	2.8 (71)	9.7 (246)	10.4 (264)	15.7 (399)	16.2 (412)	7.3 (185)	10.2 (259)	3.8 (97)	2.9 (74)
3 (80)	3.0 (76)	10.9 (277)	12.0 (305)	16.3 (414)	18.5 (470)	5.8 (147)	13.8 (351)	3.9 (99)	3.6 (91)
4 (100)	3.0 (76)	12.2 (310)	13.1 (333)	16.5 (419)	21.0 (533)	5.1 (129)	16.8 (427)	4.5 (114)	4.3 (109)
6 (150)	4.5 (114)	13.6 (345)	15.0 (381)	18.4 (467)	24.8 (630)	3.4 (86)	22.4 (569)	5.9 (150)	5.7 (145)
8 (200)	5.3 (135)	16.3 (414)	17.2 (437)	19.5 (495)	29.1 (739)	2.9 (74)	27.5 (699)	5.2 (132)	6.7 (170)

**Notes:**

1. Dimensions are based on drain valves being open.
2. Dimensions do not provide installation clearance.



**FIGURE 4B**  
**DV-5A VALVE - DOUBLE INTERLOCK PREACTION ELECTRIC/ELECTRIC ACTUATION TRIM**  
**WITH MODEL QRS ELECTRONIC ACCELERATOR OPTIONAL COMPONENTS**  
**INSTALLATION DIMENSIONS**

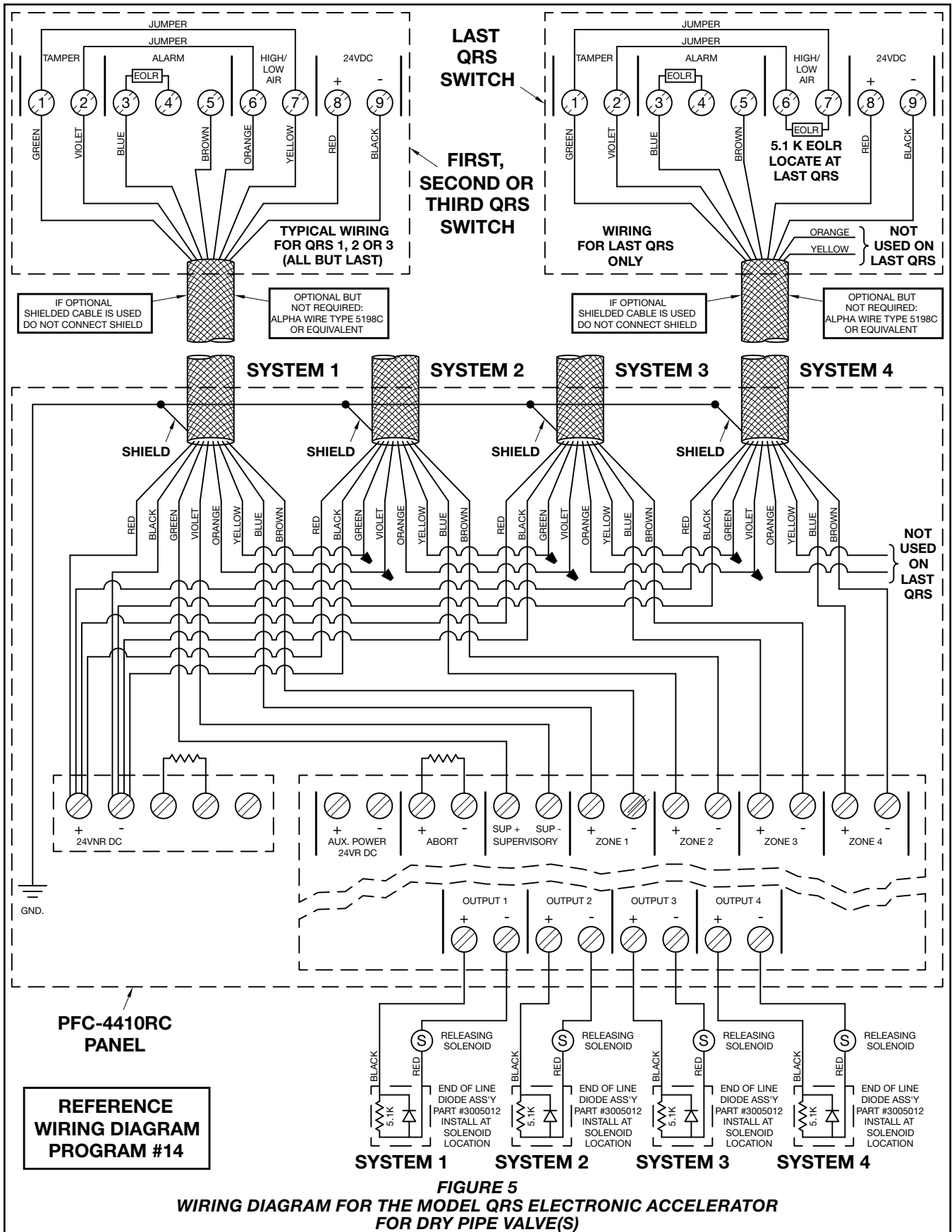

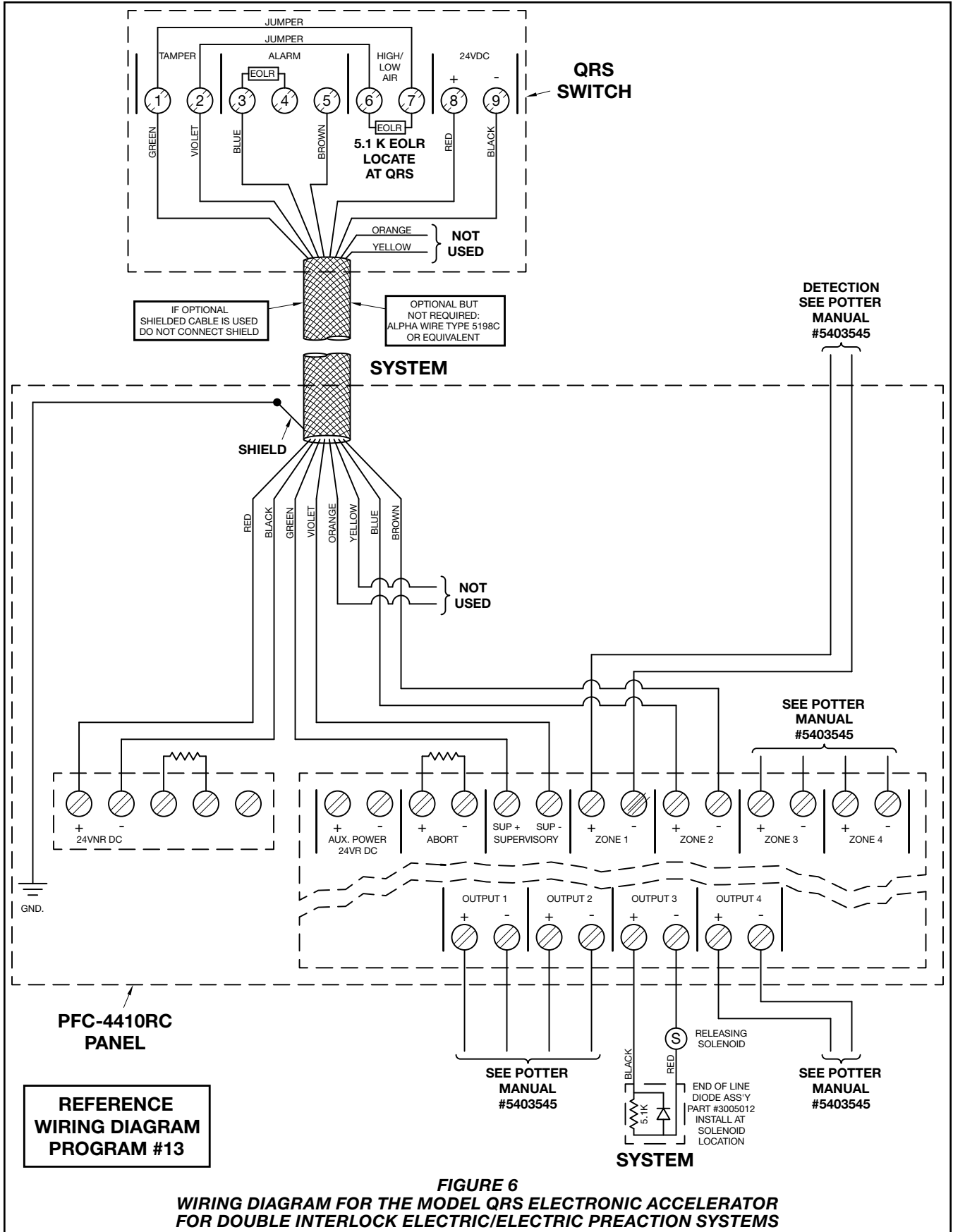

## Setting Procedure (Dry Pipe System)

The dry pipe system and the TYCO Model QRS Electronic Accelerator must be reset and restored to service as soon as possible after an operation.

### NOTICE

*The system must be completely drained before proceeding.*

*In the case of one panel serving multiple risers, whenever the Program Switch is set to the PROGRAM position (Steps 4 and 7), the QRS switch are taken out of service for all connected system risers. Therefore, the proper authorities and all personnel who may be affected must be notified. In the event of a fire and where a QRS switch has been taken out of service, an increased time in water delivery can be expected.*

**Step 1.** Until the system is to be set for service, the internal audible buzzer may be silenced by momentarily pressing the BUZZER SILENCE button (Figure 7).

**Step 2.** Locate all of the system's low point drain valves to help facilitate resetting the system.

**Step 3.** Follow the resetting procedure for the dry pipe valve using the instructions provided in the Technical Data Sheet for the dry pipe valve. When prompted to pressurize the system piping with air, proceed with Step 4.

**Step 4.** Momentarily press the SYSTEM RESET button (Figure 7) and then set the program switch to the PROGRAM position. The display will read "OK to charge system." Begin applying air pressure to the system. At this point the solenoid valve will be de-energized and allowed to close to enable pressurization of the system piping, and a 30 minute countdown to repressurize the system will be displayed.

### NOTICE

*If within 30 minutes, the program switch is not returned to the RUN position during the upcoming Step 6, the releasing panel will automatically revert to a normal condition. If at least 8 psi has not been reached, the solenoid valve will be energized and open. If at least the low air pressure threshold of Table A has not been reached, a supervisory condition will occur.*

*If more than 30 minutes is required, the counter can be restarted before the 30 minutes has elapsed. In order to reset the counter, the system must be pressurized to at least 8 psi, at which time the program switch can be set to the RUN position and then quickly back to the PROGRAM position. A 30 minute countdown will then be restarted.*

**Step 5.** When the system reaches an air pressure of approximately 10 psi, and while the system is in process of reaching its intended pressure, "blow-down" each drain valve one at a time, including the low body drain or priming level valve, at the dry pipe valve and the inspector's test connection by opening each drain valve until water ceases to drain and then closing the drain valve. The blow-down procedure that will assure complete draining of the system will be more easily accomplished with 10 psi air pressure in the system.

**Step 6.** When the system reaches the intended pressure and the pressure is stabilized, return the program switch (Figure 7) to the RUN position.

**Step 7.** After waiting at least 60 seconds, open the inspector's test connection, wait 5 seconds, and then close the Inspector's Test Connection.

Verify that the time to accelerator trip is essentially the same as in previous tests. A momentary burst of air from a dry pipe valve's automatic drain valve indicates that the QRS switch has tripped. In addition, the display on the operating interface of the releasing panel will indicate operation. This procedure clears any scale and debris from the pipe and nipples that are connected to the solenoid valve.

Momentarily press the SYSTEM RESET button and then set the program switch to the PROGRAM position. The display will read "OK to charge system". At this point, the solenoid valve will be de-energized and allowed to close to enable pressurization of the system piping.

Allow the system to automatically return to its intended pressure via its automatic air supply, and, after waiting for the pressure to stabilize, return the program switch to the RUN position.

**Step 8.** Partially open the main control valve. Slowly close the system main drain valve as soon as water discharges from the drain connection.

Depress the plunger on the dry pipe valve's automatic drain valve to make sure that it is open and that no water discharges. The absence of water discharge from the automatic drain valve is an indication of a properly set water seat within the dry pipe valve. If water is discharging, refer to the Care and Maintenance section of the Technical Data Sheet for the dry pipe valve to determine and correct the cause of the leakage problem.

If there are no leaks, the system main control valve must be fully opened.

The system is now set for service.

*NOTE: After setting a fire protection system, notify the proper authorities and advise those responsible for monitoring proprietary and/or central station alarms.*

## Setting Procedure (Preaction System)

The Double Interlock Electric/Electric Preaction System and the Model QRS Electronic Accelerator must be reset and restored to service as soon as possible after an operation.

Follow the Valve Setting Procedure instructions provided in the Technical Data Sheet TFP1466. When prompted to reset the actuation system, momentarily press the system reset button (Figure 7), and assuming that the zone 1 alarm and zone 2 low air alarm are clear, proceed with the remaining instructions provided in Technical Data Sheet TFP1466.

*NOTE: After setting a fire protection system, notify the proper authorities and advise those responsible for monitoring proprietary and/or central station alarms.*

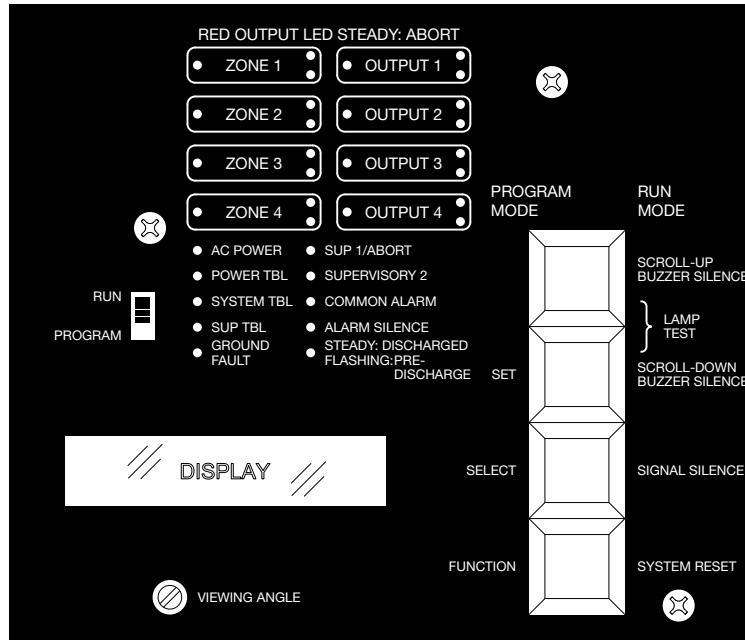

**FIGURE 7**  
**OPERATING INTERFACE FOR THE MODEL PFC-4410RC RELEASING PANEL**

## Care and Maintenance

The following procedures and inspections should be performed as indicated, in addition to any specific requirements of the NFPA, and any impairment must be immediately corrected.

The owner is responsible for the inspection, testing, and maintenance of their fire protection system and devices in compliance with this document, as well as with the applicable standards of the NATIONAL FIRE PROTECTION ASSOCIATION, for example, NFPA 25, in addition to the standards of any authority having jurisdiction. Contact the installing contractor or product manufacturer with any questions.

It is recommended that automatic sprinkler systems be inspected, tested, and maintained by a qualified Inspection Service.

The Model QRS Electronic Accelerator must be maintained and serviced in accordance with this section.

### NOTICE

The QRS uses electronic components to monitor the system air pressure. Keep all radio transmitters or RF sources at least one foot from the QRS switch. Failure to do so could result in an unintended operation of the dry pipe or preaction system.

Before closing a fire protection system main control valve for inspection or maintenance work on the fire protection system that it controls, permission to shut down the affected fire protection system must be obtained from the proper authorities and all personnel who may be affected by this action must be notified.

If an Accelerator is to be temporarily taken out of service, the proper authorities and all personnel who may be affected must be notified.

### Model QRS Electronic Accelerator Testing Procedure

It is recommended that the following Accelerator test procedure be performed quarterly.

**Step 1.** When operation of the dry pipe/preaction valve is not intended during the accelerator trip test, close the system main control valve and open the system main drain valve to relieve the supply pressure to the dry pipe/preaction valve. Otherwise, proceed as follows.

**Step 2.** For a dry pipe system, open the inspector's test connection. Verify that the time to accelerator trip is essentially the same as in previous tests. A momentary burst of air from a dry pipe valve's automatic drain valve indicates that the accelerator has tripped. In addition, the display on the operating interface of the releasing panel will indicate operation.

For a double interlock electric/electric preaction system, first operate the detection system and then open the inspector's test connection. Verify that the time to accelerator trip is essentially the same as in previous tests. Release of the DV-5A valve diaphragm pressure through the open solenoid valve indicates that the accelerator has tripped. In addition, the display on the operating interface on the releasing panel will indicate operation.

**Step 3.** Reset the Model QRS Electronic Accelerator in accordance with the appropriate Setting Procedure section.

### Releasing Panel and Batteries

Inspect, test, and maintain per the instructions provided for the Model PFC-4410RC Releasing Panel.

**NOTES:**

1. Installation notes are typical of all Dry Pipe Valve models shown.
2. Some items provided with the Model QRS Trim (P/N 52-312-2-001) are not used for the purposes of retrofit and may be discarded. Field fabrication of additional materials will be required to facilitate connection to the existing system riser accelerator connection.

NO	DESCRIPTION	QTY	P/N
1	Quick Release Switch, Model QRS .....	1	92-312-1-001
2	Solenoid Valve .....	1	52-287-1-024
3	1/2" Union .....	2	CH
4	1/2" Tee .....	1	CH
6	1/2" x Close Nipple .....	2	CH

CH: Common Hardware

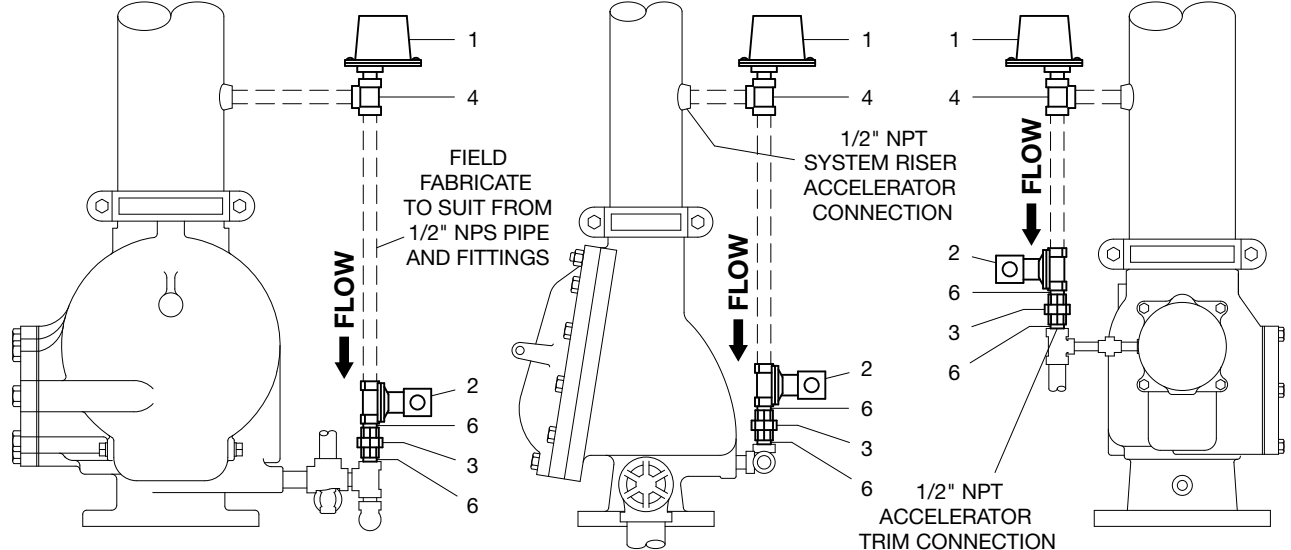

**RIGHT SIDE VIEW**

Refer to Data Sheets:  
 Central 3 Inch Model AF, 10-3.2 (7-96),  
 and 4 & 6 Inch Model AF/AG,  
 10-4.0 (7-96) or 10-5.0 (7-96),  
 Star Model A-1  
 2-2.1.31 (2-00) 4 Inch  
 2-2.1.41 (2-00) 6 Inch

**RIGHT SIDE VIEW**

Refer to Data Sheets:  
 Star Model A  
 2-2.1.30 (6-97) 4 Inch  
 2-2.1.40 (6-97) 6 Inch

**LEFT SIDE VIEW**

Refer to Data Sheet:  
 Gem 4 & 6 Inch  
 Model F302/F3021  
 TD107 (11-97)

**FIGURE 8**  
**MODEL QRS ELECTRONIC ACCELERATOR RISER COMPONENTS**  
**INSTALLATION DIAGRAM WITH DRY PIPE VALVES**  
**MANUFACTURED BY TYCO OTHER THAN THE MODEL DPV-1 DRY PIPE VALVE**

# Limited Warranty

For warranty terms and conditions, visit  
www.tyco-fire.com.

# Ordering Procedure

## Dry Pipe Valve

### Electronic Accelerator Package with 12AH Battery Backup

The required components for one dry pipe valve riser include the following (see Figure 1):

- Model QRS Electronic Accelerator Trim, P/N 52-312-2-001
- Model PFC-4410RC Releasing Panel, P/N 20135
- Model BT-120 12AH Battery, P/N 20128 (quantity of 2 provided)

Specify: Model QRS Electronic Accelerator Package, 12AH Battery Backup, P/N 52-312-2-102

## Dry Pipe Valve

### Electronic Accelerator Package with 18AH Battery Backup

The required components for one dry pipe valve riser include the following (see Figure 1):

- Model QRS Electronic Accelerator Trim, P/N 52-312-2-001
- Model PFC-4410RC Releasing Panel, P/N 20135
- Model BT-180 18AH Battery, P/N 20121, (quantity of 2 provided)

Specify: Model QRS Electronic Accelerator Package, 18AH Battery Backup, P/N 52-312-2-103

## Dry Pipe Valve

### Electronic Accelerator Trim

One each is required for each additional dry pipe riser, for up to three additional dry pipe risers.

**Note:** Does not include Potter PFC-4410RC Panel and BT120 or BT180 batteries.

Specify: Model QRS Electronic Accelerator Trim, P/N 52-312-2-001

### Replacement Trim Parts

(Specify description) for use with Model QRS Electronic Accelerator Dry Pipe Valve, P/N (specify, see Figure 2)

### Separately Ordered Model QRS Quick Release Switch Equipment for use with DV-5A Valve Double Interlock Preaction Electric/Electric Actuation Trim

When ordering Model QRS Quick Release Switch equipment for use with the DV-5A Valve Double Interlock Preaction Electric/Electric Actuation Trim, the QRS equipment and DV-5A Valve and Trim must be ordered separately. Specify:

- DV-5A Double Interlock Electric/Electric Trim, P/N (specify per Technical Data Sheet TFP1466)
- Model QRS Quick Release Switch, P/N 92-312-1-001
- Model PFC-4410RC Releasing Panel, P/N 20135
- Model BT-120 12AH Battery, P/N 20128 (quantity of 2 provided)

### Pre-Trimmed DV-5A Valve Double Interlock Preaction Electric/Electric Actuation Assembly with Butterfly Valve and Model QRS Quick Release Switch

**Note:** Does not include Potter PFC-4410RC Panel and BT120 batteries.

Specify: (specify size), G x G End Connection, Pre-Trimmed DV-5A Assembly with Butterfly Valve and Model QRS Quick Release Switch, P/N (specify):

1-1/2 in. G x G	.....	55-101-1-515Q
2 in. G x G	.....	55-101-1-520Q
3 in. G x G	.....	55-101-1-530Q
4 in. G x G	.....	55-101-1-540Q
6 in. G x G	.....	55-101-1-560Q
8 in. G x G	.....	55-101-1-580Q

### Pre-Trimmed DV-5A Valve Double Interlock Preaction Electric/Electric Actuation Assembly with Model QRS Quick Release Switch

**Note:** Does not include Potter PFC-4410RC Panel and BT120 batteries.

Specify: (specify size), F x G End Connection, Pre-Trimmed DV-5A Assembly with Model QRS Quick Release Switch, P/N (specify):

3 in. F x G	.....	55-003-1-530Q
4 in. F x G	.....	55-003-1-540Q
6 in. F x G	.....	55-003-1-560Q
8 in. F x G	.....	55-003-1-580Q

### Pre-Trimmed DV-5A Valve Double Interlock Preaction Electric/Electric Actuation Assembly with Model QRS Quick Release Switch, without Butterfly Valve

**Note:** Does not include Potter PFC-4410RC Panel and BT120 batteries.

Specify: (specify size), G x G End Connection, Pre-Trimmed DV-5A Assembly with Model QRS Quick Release Switch, P/N (specify):

1-1/2 in. G x G	.....	55-001-1-515Q
2 in. G x G	.....	55-001-1-520Q
3 in. G x G	.....	55-001-1-530Q
4 in. G x G	.....	55-001-1-540Q
6 in. G x G	.....	55-001-1-560Q
8 in. G x G	.....	55-001-1-580Q

### Replacement Trim Parts

(Specify description) for use with Model QRS, DV-5A Electric/Electric Preaction, P/N (specify, see Figure 3A)





## TFP1100 Change History Appendix

ISSUE DATE	NOTES
08-22	Throughout, updated DV-5A Double Interlock Electric/Electric Trim data sheet number to TFP1466, formerly shown as TFP1450; Page 1, added QR code and URL to allow convenient access to electronic version from printed document; Page 16, changed corporate address and telephone number to 1467 Elmwood Avenue, Cranston, RI 02910   Telephone +1-401-781-8220, formerly 1400 Pennbrook Parkway, Lansdale, PA 19446   Telephone +1-215-362-0700.
09-21	Page 16, updated part numbers for Pre-Trimmed DV-5A Double Interlock Electric/Electric Actuation Preaction Valve with Model QRS Quick Release Switch section: 3 in. F x G, 55-003-1-530Q, formerly 55-103-1-530Q; 4 in. F x G, 55-003-1-540Q, formerly 55-103-1-540Q; 6 in. F x G, 55-003-1-560Q, formerly 55-103-1-560Q; 8 in. F x G, 55-003-1-580Q, formerly 55-103-1-580Q.
03-19	Replaced DV-5 with DV-5A trim arrangements.
08-18	Updated Tyco® branding and document format; Added Johnson Controls copyright; Added disclaimer stating specifications and information subject to change without notice; Added reference to Regulatory and Health Warning Technical Data Sheet TFP2300.
12-14	Added option for 18AH battery back-up; Added pre-assembled DV-5 double interlock preaction electric/electric actuation valves.
05-09	Updated Table A for High/Low Pressure Settings; Added trim arrangements for DV-5 Double Interlock Electric/Electric Preaction Systems with QRS Electronic Accelerator, P/N 52-478-2-128Q for 1-1/2 and 2 in. systems, P/N 52-478-2-125Q for 3 in. systems, P/N 52-478-2-122Q for 4, 6, and 8 in. systems; Updated wiring diagrams and setting procedure instructions for the current Potter PFC-4410-RC Control Panel; Added NOTICE indicating wiring must be terminated (landed) while PFC-4410-RC panel is de-energized.
05-06	Updated to indicate one control panel can be used for up to four Dry Pipe Systems or for one cross-zoned Model DV-5 Electric/Electric Double Interlock Preaction System.
08-03	Added wiring materials specifications for connecting QRS Switch to Releasing Control Panel.
03-03	New Technical Data Sheet TFP1100 describes Model QRS Electronic Dry Pipe Valve Accelerator.