

## Series LFII Residential Sprinkler 4.4 K-factor Horizontal Sidewall, Dry Type Wet Pipe System

### IMPORTANT

Refer to Technical Data Sheet TFP2300 for warnings pertaining to regulatory and health information. Always refer to Technical Data Sheet TFP700 for the "INSTALLER WARNING" that provides cautions with respect to handling and installation of sprinkler systems and components. Improper handling and installation can permanently damage a sprinkler system or its components and cause the sprinkler to fail to operate in a fire situation or cause it to operate prematurely.

Scan the QR code or enter the URL in a web browser to access the most up-to-date electronic version of this document. Data rates may apply.



[docs.jci.com/tycofire/TFP461](http://docs.jci.com/tycofire/TFP461)

### General Description

The TYCO Series LFII Dry Type Residential Horizontal Sidewall (HSW) Sprinklers (TY2335) are dry-type decorative, fast response, frangible bulb sprinklers designed for use in residential occupancies such as homes, apartments, dormitories, and hotels.

The Series LFII Dry Type Residential Horizontal Sidewall Sprinklers are typically used where sprinklers and/or a portion of the connecting piping are exposed to freezing temperatures (for example, horizontal sprinkler supplied from wet systems into unheated areas).

The Series LFII Dry Type Residential Horizontal Sidewall Sprinklers are intended for use in Residential Sprinkler systems for one- and two-family dwellings and mobile homes per NFPA 13D; residential sprinkler systems for residential occupancies up to and including four stories in height per NFPA 13R; or, sprinkler systems for the residential portions of any occupancy per NFPA 13.

The recessed version is intended for use in areas with finished walls. It employs a two-piece Style 20 Recessed Escutcheon. The Recessed Escutcheon provides 1/4 in. (6,4 mm) of recessed adjustment or up to 1/2 in. (12,7 mm) of total adjustment from the flush mounting surface position. The design of this escutcheon provides a level of flexibility in adjusting sprinkler supply connections.

The Series LFII Dry Type Residential Horizontal Sidewall Sprinklers have been designed with heat sensitivity and water characteristics proven to help in the control of residential fires and to improve the chance for occupants to escape or be evacuated.

Corrosion-resistant coatings, where applicable, are utilized to extend the life of copper alloy sprinklers beyond that which would otherwise be obtained when exposed to corrosive atmospheres. Although corrosion-resistant coated sprinklers have passed the standard corrosion tests of the applicable Approval agencies, the testing is not representative of all possible corrosive atmospheres. Consequently, it is recommended that the end user be consulted with respect to the suitability of these coatings for any given corrosive environment. The effects of ambient temperature, concentration of chemicals, and gas/chemical velocity should be considered, as a minimum, along with the corrosive nature of the chemical to which the sprinklers will be exposed.

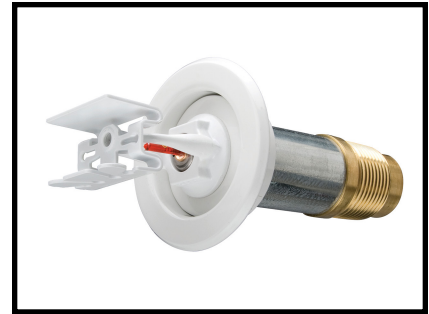

### NOTICE

The Series LFII Dry Type Residential Horizontal Sidewall Sprinklers (TY2335) described herein must be installed and maintained in compliance with this document and the applicable standards of the NATIONAL FIRE PROTECTION ASSOCIATION (NFPA), in addition to the standards of any authorities having jurisdiction. Failure to do so may impair the performance of these devices.

The owner is responsible for maintaining their fire protection system and devices in proper operating condition. Contact the installing contractor or product manufacturer with any questions.

### Sprinkler Identification Number (SIN)

TY2335

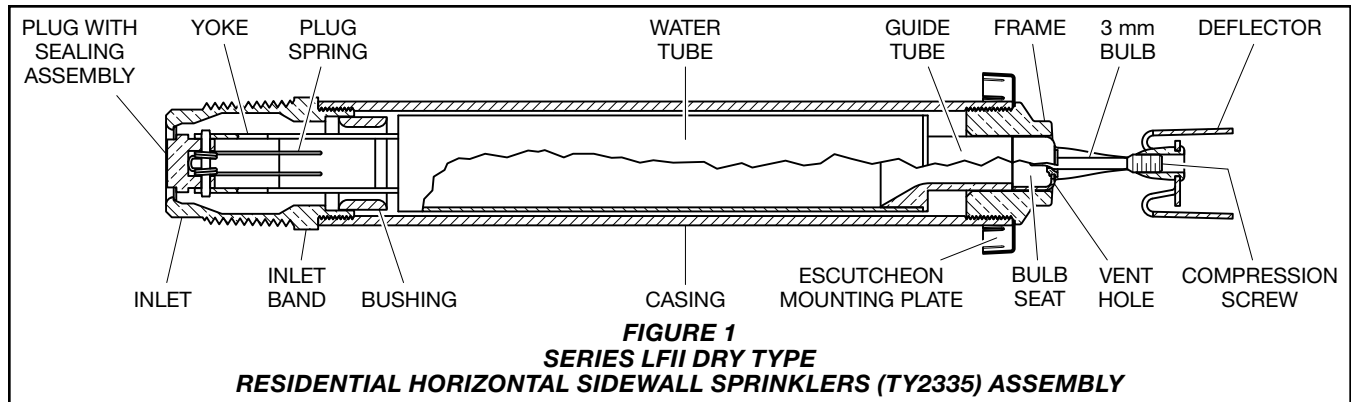

**FIGURE 1**  
**SERIES LFII DRY TYPE**  
**RESIDENTIAL HORIZONTAL SIDEWALL SPRINKLERS (TY2335) ASSEMBLY**

## Technical Data

### Approvals

UL and C-UL Listed  
 Certified to all requirements of NSF/ANSI 61

**Note:** Sprinklers with a polyester finish are UL and C-UL Listed as corrosion-resistant sprinklers.

See the Design Criteria section for details on these approvals.

### Maximum Working Pressure

175 psi (12,1 bar)

### Discharge Coefficient

$K=4.4 \text{ GPM/psi}^{1/2}$  (63,4 LPM/bar<sup>1/2</sup>)

### Inlet Thread Connections

1 in. NPT  
 ISO 7-R 1

### Sprinkler Temperature Rating

155°F (68°C)

### Finishes

Natural Brass, Signal White Polyester Coated, or Chrome Plated

### Order Lengths

Minimum: 3-3/4 in. (95,3 mm)  
 Maximum: 24 in. (609,6 mm)

### Physical Characteristics

Inlet .....	Brass
Plug .....	Brass
Yoke .....	Stainless Steel
Casing .....	Galvanized Steel
Insert .....	Bronze
Bulb Seat .....	Stainless Steel
Bulb .....	Glass
Compression Screw .....	Brass
Deflector .....	Brass
Frame .....	Brass
Guide Tube .....	Stainless Steel
Water Tube .....	Stainless Steel
Bushing .....	Brass
Plug Spring .....	Stainless Steel
Sealing Assembly .....	Beryllium Nickel w/TEFLON
Escutcheon .....	Carbon Steel

## Operation

When the TYCO Series LFII Dry Type Residential Horizontal Sidewall Sprinkler is in service, water is prevented from entering the assembly by the Plug with Sealing Assembly (see Figure 1) in the Inlet of the Sprinkler.

The glass Bulb contains a fluid that expands when exposed to heat. When the rated temperature is reached, the fluid expands sufficiently to shatter the glass Bulb to release the Bulb Seat. The system's water pressure is then able to unseat the Plug with Sealing Assembly. The Plug Spring turns the Plug with Sealing Assembly aside, allowing the sprinkler to activate and flow water.

## Design Criteria

The TYCO Series LFII Dry Type Residential Horizontal Sidewall Sprinklers (TY2335) are UL and C-UL Listed for installation in accordance with this section.

### Residential Sprinkler Design Guide

When conditions exist that are outside the scope of the criteria provided in this section, refer to the technical data sheet entitled Residential Sprinkler Design Guide (TFP490) for the manufacturer's recommendations that may be acceptable to the local authority having jurisdiction.

### System Type

Wet Pipe

### Hydraulic Design (NFPA 13D and 13R)

For systems designed to NFPA 13D or NFPA 13R, the minimum required sprinkler flow rates are given in Table A as a function of temperature rating and the maximum allowable coverage areas. The sprinkler flow rate is the minimum required discharge from each of the total number of design sprinklers, as specified in NFPA 13D or NFPA 13R.

### Hydraulic Design (NFPA 13)

For systems designed to NFPA 13, the number of required design sprinklers is the four most hydraulically demanding sprinklers. The minimum required discharge from each of the four sprinklers is the greater of the following:

- flow rates listed in Table A as a function of temperature rating and the maximum allowable coverage area.
- minimum discharge of 0.1 gpm/ft<sup>2</sup> over the design area comprised of the four most hydraulically demanding sprinklers for the actual coverage areas protected by four sprinklers.

### Obstruction to Water Distribution

Sprinklers are to be located in accordance with the obstruction rules of NFPA 13D, 13R, and 13 as applicable for residential sprinklers as well as with the obstruction criteria described within the Technical Data Sheet TFP490.

### Operational Sensitivity

The sprinkler must be located relative to the mounting surface as shown in Figures 2 and 3.

### Sprinkler Spacing

The minimum lateral spacing between sprinklers is 8 ft (2,4 m). The maximum lateral spacing between sprinklers cannot exceed the length of the coverage area (see Table A) hydraulically calculated (for example, a maximum of 12 ft for a 12 ft x 12 ft coverage area or 18 ft for a 18 ft x 20 ft coverage area.)

### Sprinkler Fittings

The following fittings may be used:

- the 1 in. NPT outlet or run of a malleable or ductile iron threaded tee fittings that meet the dimensional requirements of ANSI B16.3 (Class 150)
- the 1 in. NPT outlet or run of a cast iron threaded tee fitting that meet the dimensional requirements of ANSI B16.4 (Class 125)

Do not install the Series LFII Dry Type Residential Horizontal Sidewall Sprinklers into elbow fittings. The Inlet of the sprinkler can contact the interior of the elbow, potentially damaging the Inlet seal.

Only use the configuration in Figure 4 where the sprinkler fitting and water-filled pipe at the sprinkler fitting are

Maximum Coverage Area <sup>(a,b)</sup> Width x Length ft x ft (m x m)	Maximum Spacing ft (m)	WET PIPE SYSTEM Minimum Flow and Residual Pressure <sup>(c,d)</sup> 155°F (68°C)				
		Flow gpm (lpm)	Pressure psi (bar)	Deflector to Ceiling	Installation Type	Minimum Spacing ft (m)
12 x 12 (3,7 x 3,7)	12 (3,7)	13 (49,2)	8.7 (0,60)	4 in. to 6 in.	Recessed or Plain Barreled	8 (2,4)
14 x 14 (4,3 x 4,3)	14 (4,3)	14 (53,0)	10.1 (0,70)			
16 x 16 (4,9 x 4,9)	16 (4,9)	18 <sup>(e)</sup> (68,1)	16.7 <sup>(e)</sup> (1,15)			
16 x 18 (4,9 x 5,5)	16 (4,9)	21 <sup>(g)</sup> (79,5)	22.8 <sup>(g)</sup> (1,57)			
16 x 20 (4,9 x 6,1)	16 (4,9)	25 (94,6)	32.3 (2,23)			
12 x 12 (3,7 x 3,7)	12 (3,7)	15 (56,8)	11.6 (0,80)	6 in. to 12 in.		
14 x 14 (4,3 x 4,3)	14 (4,3)	16 <sup>(f)</sup> (60,6)	13.2 <sup>(f)</sup> (0,91)			
16 x 16 (4,9 x 4,9)	16 (4,9)	19 (71,9)	18.6 (1,28)			
16 x 18 (4,9 x 5,5)	16 (4,9)	22 <sup>(h)</sup> (83,3)	25 <sup>(h)</sup> (1,72)			
16 x 20 (4,9 x 6,1)	16 (4,9)	30 <sup>(i)</sup> (113,6)	46.5 <sup>(i)</sup> (3,20)			

**Notes:**  
a. For coverage area dimensions less than or between those indicated, use the minimum required flow for the next highest coverage area for which hydraulic design criteria are stated.  
b. This dimension refers to the Width (backwall where the sprinkler is located) times the Length (horizontal throw of the sprinkler).  
c. The requirement is based on minimum flow in gpm (lpm) from each sprinkler. The associated residual pressures are calculated using the nominal K-factor. See Hydraulic Design under the Design Criteria section for details.  
d. For NFPA 13 residential applications, the greater of 0.1 gpm/ft<sup>2</sup> over the design area or the flow in accordance with the criteria in this table must be used.  
e. For sprinklers installed prior to May 1, 2015, a flow rate of 17 gpm at a pressure of 14.9 psi may be used.  
f. For sprinklers installed prior to May 1, 2015, a flow rate of 15 gpm at a pressure of 11.6 psi may be used.  
g. For sprinklers installed prior to May 1, 2015, a flow rate of 19 gpm at a pressure of 18.6 psi may be used.  
h. For sprinklers installed prior to May 1, 2015, a flow rate of 20 gpm at a pressure of 20.7 psi may be used.  
i. For sprinklers installed prior to May 1, 2015, a flow rate of 25 gpm at a pressure of 32.3 psi may be used.

**TABLE A  
WET PIPE SYSTEM  
SERIES LFII DRY TYPE HORIZONTAL SIDEWALL SPRINKLERS  
NFPA 13D, 13R AND 13 HYDRAULIC DESIGN CRITERIA**

Ambient Temperature Exposed to Discharge End of Sprinkler	Temperatures for Heated Area <sup>(1)</sup>		
	40°F (4°C)	50°F (10°C)	60°F (16°C)
	Minimum Exposed Barrel Length <sup>(2)</sup> , in. (mm)		
40°F (4°C)	0	0	0
30°F (-1°C)	0	0	0
20°F (-7°C)	4 (100)	0	0
10°F (-12°C)	8 (200)	1 (25)	0
0°F (-18°C)	12 (305)	3 (75)	0
-10°F (-23°C)	14 (355)	4 (100)	1 (25)
-20°F (-29°C)	14 (355)	6 (150)	3 (75)
-30°F (-34°C)	16 (405)	8 (200)	4 (100)
-40°F (-40°C)	18 (455)	8 (200)	4 (100)
-50°F (-46°C)	20 (510)	10 (255)	6 (150)
-60°F (-51°C)	20 (510)	10 (255)	6 (150)

**Notes:**  
1. For protected area temperatures that occur between values listed above, use the next cooler temperature.  
2. These lengths are inclusive of wind velocities up to 30 mph (18,6 kph).

**TABLE B  
MINIMUM RECOMMENDED LENGTHS OF EXPOSED SPRINKLER BARRELS IN WET PIPE SYSTEMS**

not subject to freezing and where the length of the Series LFII Sprinkler has the minimum exposure length per Figure 5. See the Exposure Length section and Table B.

- the 1 in. NPT outlet of a GRINNELL Figure 730 Mechanical Tee in wet pipe systems only
- the 1 in. NPT CPVC outlet of a 1 in. x 1 in. x 1 in. NPT Sprinkler Head Adapter Tee (P/N 80249) in wet systems only
- the 1 in. NPT CPVC outlet of a 1 in. x 1 in. NPT Female Adapter (P/N 80145) in wet systems only
- the 1 in. NPT outlet of a 1 in. x 1 in. x 1 in. NPT CPVC Sprinkler Head Adapter Tee (P/N 80259) in wet pipe systems only

**NOTICE**

*Do not install the Series LFII Dry Type Residential Horizontal Sidewall Sprinklers into any other type fitting without first consulting Johnson Controls Technical Services. Failure to use the appropriate fitting may result in the following:*

- *failure of the sprinkler to operate properly due to formation of ice over the Inlet Plug or binding of the Inlet Plug.*
- *insufficient engagement of the inlet pipe threads with consequent leakage.*

**Exposure Length**

When using Series LFII Dry Type Residential Horizontal Sidewall Sprinklers in wet pipe sprinkler systems to protect areas subject to freezing temperatures, use Table B to determine the appropriate exposed sprinkler barrel length to prevent water from freezing in the connecting pipes due to conduction. The exposed barrel length measurement must be taken from the face of the sprinkler fitting to the surface of the structure or insulation that is exposed

to the heated area. See Figure 5 for an example.

**Clearance Space**

When connecting an area subject to freezing and an area containing a wet-pipe sprinkler system, the clearance space around the sprinkler barrel of Dry Type Residential Sprinklers must be sealed, in accordance with the NATIONAL FIRE PROTECTION ASSOCIATION. Due to temperature differences between the two areas, the potential for the formation of condensation in the sprinkler and subsequent ice build-up is increased. If this condensation is not controlled, ice build-up can occur that might damage the dry type sprinkler and/or prevent proper operation in a fire situation.

Use of the Model DSB-2 Dry Sprinkler Boot, described in Technical Data Sheet TFP591 and shown in Figures 4 and 5, can provide the recommended seal.

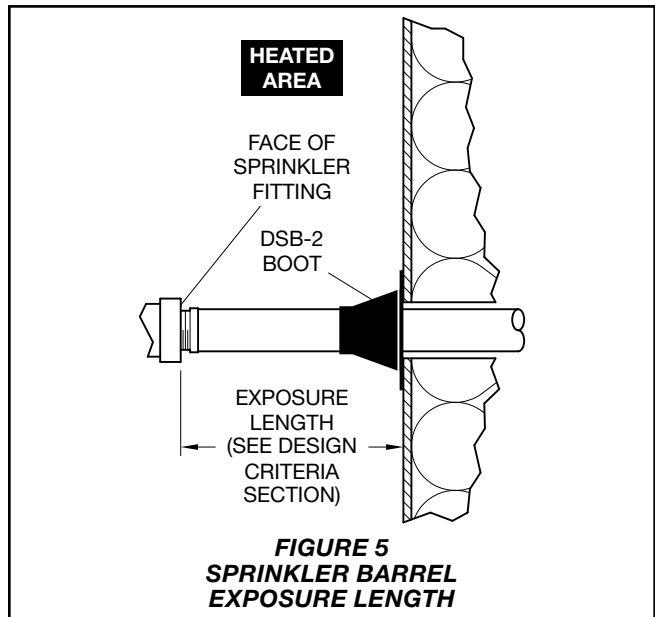
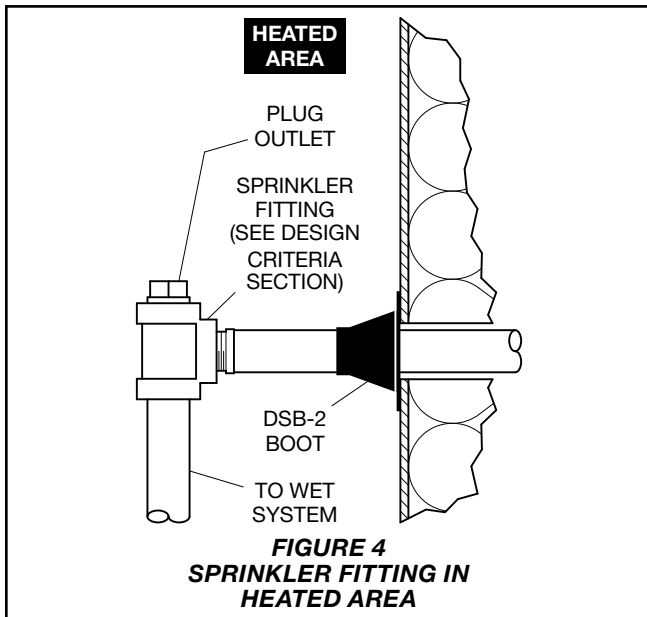
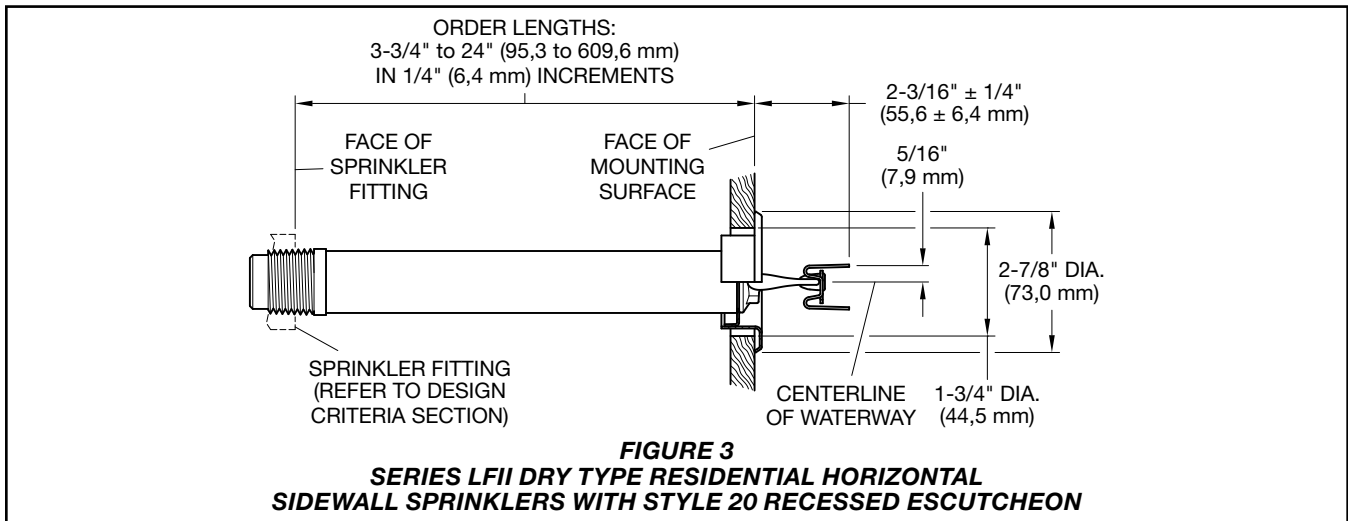
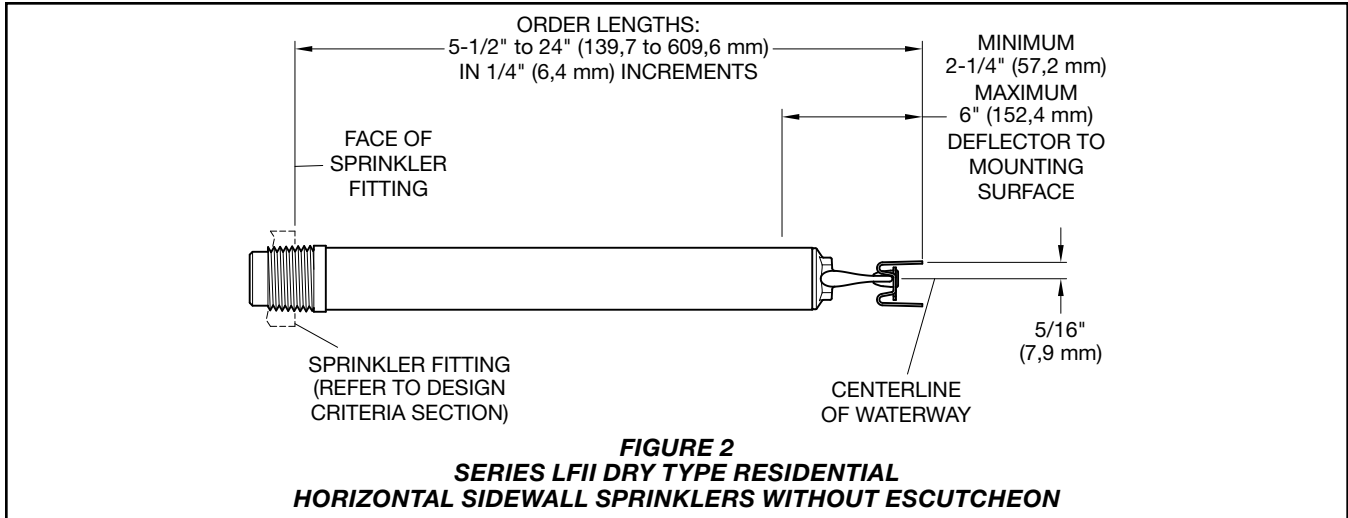

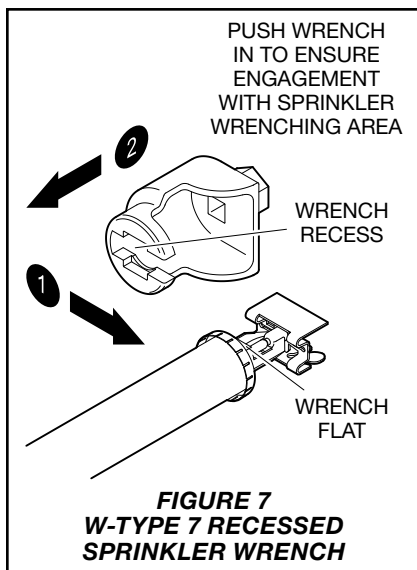
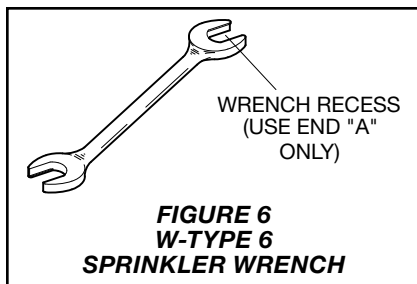

## Installation

TYCO Series LFII Dry Type Residential Horizontal Sidewall Sprinklers must be installed in accordance with this section.

### General Instructions

The Series LFII Dry Type Residential Horizontal Sidewall Sprinklers must only be installed in fittings that meet the requirements of the Design Criteria section. For other important requirements regarding piping design and sealing of the clearance space around the Sprinkler Casing, see the Design Criteria section.

Do not install any bulb type sprinkler if the Bulb is cracked or there is a loss of liquid from the Bulb. With the sprinkler held horizontally, a small air bubble should be present. The diameter of the air bubble is approximately 1/16 in. (1,6 mm).

A leak-tight 1 in. NPT sprinkler joint should be obtained by applying a minimum-to-maximum torque of 20 to 30 lb-ft (26,8 to 40,2 N·m). Higher levels of torque can distort the sprinkler Inlet or Frame with consequent leakage or impairment of the sprinkler.

Do not attempt to compensate for insufficient adjustment in an Escutcheon Plate by under- or over-tightening the sprinkler. Re-adjust the position of the sprinkler fitting to suit.

**Note:** Install horizontal sidewall sprinklers only in the horizontal position with their centerline of waterway parallel to the ceiling. The word TOP on the Deflector is to face towards the ceiling.

**Step 1.** With a non-hardening pipe-thread sealant such as Teflon tape applied to the inlet threads, hand-tighten the sprinkler into the sprinkler fitting.

**Step 2.** Wrench-tighten the sprinkler using a pipe wrench on the Inlet Band or the Casing (see Figure 1), or using the W-Type 6 or W-Type 7 Sprinkler Wrench as follows:

- For plain-barrel horizontal sidewall sprinklers, apply the Wrench Recess End "A" of the W-Type 6 Sprinkler Wrench (see Figure 6) to the Wrench Flat.
- For recessed horizontal sidewall sprinklers, apply the Wrench Recess of the W-Type 7 Sprinkler Wrench to the Wrench Flat (see Figure 7).

If sprinkler removal is necessary, remove the sprinkler using the same wrenching method noted above. Sprinkler removal is easier when a non-hardening sealant was used and torque guidelines were followed. After removal, inspect the sprinkler for damage.

**Step 3.** After installation of the gypsum board or other wall/soffit finish material, slide the Style 20 Recessed Escutcheon Closure over the sprinkler. Push the closure over the mounting plate until its flange contacts the wall.

## Care and Maintenance

TYCO Series LFII Dry Type Residential Horizontal Sidewall Sprinklers (TY2335) must be maintained and serviced in accordance with this section.

Before closing a fire protection system main control valve for maintenance work on the fire protection system that it controls, obtain permission to shut down the affected fire protection systems from the proper authorities and notify all personnel who may be affected by this action.

Absence of a Recessed Escutcheon Plate or a Domed Concealed Cover Plate to cover a clearance hole can delay sprinkler operation in a fire situation.

The owner must assure that the sprinklers are not used for hanging any objects and that the sprinklers are only cleaned by means of gently dusting with a feather duster; otherwise, non-operation in the event of a fire or inadvertent operation may result.

A Vent Hole is provided in the Bulb Seat (see Figure 1) to indicate if the Series LFII Dry Type Residential Horizontal Sidewall Sprinkler is remaining dry. Evidence of leakage from the Vent Hole indicates potential leakage past the Plug with Sealing Assembly and the need to remove the sprinkler to determine the cause of leakage (e.g., an improper installation or an ice plug). Close the fire protection system control valve and drain the system before removing the sprinkler.

Sprinklers which are found to be leaking or exhibiting visible signs of corrosion must be replaced.

Automatic sprinklers must never be painted, plated, coated, or otherwise altered after leaving the factory. Modified sprinklers must be replaced. Sprinklers that have been exposed to corrosive products of combustion, but have not operated, should be replaced if they cannot be completely cleaned by wiping the sprinkler with a cloth or by brushing it with a soft bristle brush.

Care must be exercised to avoid damage to the sprinklers before, during, and after installation. Sprinklers damaged by dropping, striking, wrench twist/slippage, or the like, must be replaced. Also, replace any sprinkler that has a cracked bulb or that has lost liquid from its bulb. See the Installation section for additional information.

The owner is responsible for the inspection, testing, and maintenance of their fire protection system and devices in compliance with this document, as well as with the applicable standards of the NATIONAL FIRE PROTECTION ASSOCIATION, for example, NFPA 25, in addition to the standards of any authorities having jurisdiction. Contact the installing contractor or product manufacturer with any questions.

Automatic sprinkler systems are recommended to be inspected, tested, and maintained by a qualified Inspection Service in accordance with local requirements and/or national codes.

P/N<sup>1</sup> 63 — XXX — X — XXX

		SIN	TEMPERATURE RATING	SPRINKLER FINISH	ESCUTCHEON FINISH	ORDER LENGTH (EXAMPLES)	
12	HORIZONTAL SIDEWALL WITH RECESSED ESCUTCHEON	TY2335	1 155°F (68°C)	2 NATURAL BRASS	BRASS PLATED	055	5.50 in.
13	HORIZONTAL SIDEWALL WITHOUT ESCUTCHEON	TY2335		4 SIGNAL WHITE (RAL9003) POLYESTER <sup>2</sup>	SIGNAL WHITE (RAL9003) POLYESTER	082	8.25 in.
				9 CHROME PLATED	CHROME PLATED	180	18.00 in.
						187	18.75 in.
						240	24.00 in.

**Notes:**  
 1. Use Prefix "I" for ISO 7-R 1 Inlet Thread Connection (e.g., I-63-121-9-180)  
 2. UL and C-UL Listed as corrosion-resistant

**TABLE C**  
**SERIES LFII DRY-TYPE RESIDENTIAL HORIZONTAL SIDEWALL SPRINKLERS**  
**PART NUMBER SELECTION**

## Limited Warranty

For warranty terms and conditions, visit [www.tyco-fire.com](http://www.tyco-fire.com).

## Ordering Procedure

Contact your local distributor for availability. When placing an order, indicate the full product name and part number (P/N).

### Horizontal Sidewall Sprinkler Assemblies

**Note:** Unless otherwise indicated, see Table C.

Specify: Series LFII Dry Type Residential Horizontal Sidewall Sprinkler, SIN TY2335, with (specify Recessed or without) Escutcheon, 4.4 K-factor, Temperature Rating 155°F (68°C), Sprinkler Finish (specify), Escutcheon Finish (specify if applicable), Order Length (specify value per Figure 4 or 5), Inlet Thread Size (1 in. NPT or ISO 7-R 1), P/N (specify)

### Separately Ordered Sprinkler Wrench

Specify: W-Type 6 Sprinkler Wrench (Figure 6), P/N 56-000-6-387

Specify: W-Type 7 Recessed Sprinkler Wrench (Figure 7), P/N 56-850-4-001

### Separately Ordered Escutcheon

Specify: Style 20 Recessed Escutcheon with (specify\*) finish, P/N (specify\*)

\* Refer to Technical Data Sheet TFP770



## TFP461 Change History Appendix

ISSUE DATE	NOTES
08-22	Page 1, updated QR code and URL; Page 6, changed corporate address and telephone number to 1467 Elmwood Avenue, Cranston, RI 02910   Telephone +1-401-781-8220, formerly 1400 Pennbrook Parkway, Lansdale, PA 19446   Telephone +1-215-362-0700.
04-22	Removed RAPID RESPONSE branding throughout; Page 1, added QR code and URL to allow convenient access to electronic version from printed document; Page 2, Approvals and Design Criteria sections, Page 6, Table D, footnote 2, added C-UL Listed.
12-18	Added note indicating sprinklers with polyester finish are UL Listed as corrosion resistant sprinklers.
08-18	Updated Tyco® branding and document format; Added Johnson Controls copyright; Added disclaimer stating specifications and information subject to change without notice; Added reference to Regulatory and Health Warning Technical Data Sheet TFP2300.
03-16	Updated flow and pressure requirements shown in Table A to reflect new data resulting from testing by UL.
01-16	Added NSF/ANSI 61 certification mark.
11-15	Added NSF/ANSI 61 certification.
04-15	Removed Dry Pipe System application.
04-13	Updated and standardized RAL color finishes; Removed sloped and beamed ceiling design criteria per UL requirement.
04-12	Clarified allowance for use of horizontal ceiling hydraulic design criteria for certain slope ceiling configurations in accordance with NFPA 13D 2010 Technical Interim Amendment (TIA) 1028R; Clarified dry pipe system application.
05-11	Added ISO Inlet Thread Connection.
04-11	Updated patent information.
06-10	New Technical Data Sheet TFP461 describes Series LFII Residential Dry Type Horizontal Sidewall Sprinkler.