

Issue D QUARTZOID – 5.6 and 8.0 K-factor High Temperature, Upright and Pendent Sprinkler Standard Response, Standard Coverage

IMPORTANT

Refer to Technical Data Sheet TFP2300 for warnings pertaining to regulatory and health information.

Always refer to Technical Data Sheet TFP700 for the “INSTALLER WARNING” that provides cautions with respect to handling and installation of sprinkler systems and components. Improper handling and installation can permanently damage a sprinkler system or its components and cause the sprinkler to fail to operate in a fire situation or cause it to operate prematurely.

Scan the QR code or enter the URL in a web browser to access the most up-to-date electronic version of this document. Data rates may apply.



docs.jci.com/tycofire/TFP690

General Description

TYCO Issue D QUARTZOID 5.6K and 8.0K Upright and Pendent Sprinklers are standard response, standard coverage, 11 mm glass bulb-type spray sprinklers designed for use in light, ordinary, or extra-hazard, commercial occupancies where high ambient temperatures may be encountered.

Corrosion-resistant coatings, where applicable, are utilized to extend the life of copper alloy sprinklers beyond that which would otherwise be obtained when exposed to corrosive atmospheres. Although corrosion-resistant coated sprinklers have passed the standard corrosion tests of the applicable approval agencies, the testing is not representative of all possible corrosive atmospheres. Consequently, it is recommended that the end user be consulted with respect to the suitability of these coatings for any given corrosive environment. The effects of ambient temperature, concentration of chemicals, and gas/chemical velocity should be considered, as a minimum, along with the corrosive nature of the chemical to which the sprinklers will be exposed.

NOTICE

The Issue D QUARTZOID Sprinklers described herein must be installed and maintained in compliance with this document, as well as with the applicable standards of the NATIONAL FIRE PROTECTION ASSOCIATION (NFPA), in addition to the standards of any other authorities having jurisdiction. Failure to do so may impair the performance of these devices.

The owner is responsible for maintaining their fire protection system and devices in proper operating condition. Contact the installing contractor or product manufacturer with any questions.



Sprinkler Identification Numbers (SINs)

TY3191 . . . Upright 5.6K, 1/2 in. NPT
TY3296 . . . Pendent 5.6K, 1/2 in. NPT
TY4191 . . . Upright 8.0K, 3/4 in. NPT
TY4292 . . . Pendent 8.0K, 3/4 in. NPT

TY3191 is a re-designation for G1036
TY3296 is a re-designation for G1040
TY4191 is a re-designation for G1136
TY4292 is a re-designation for G1140

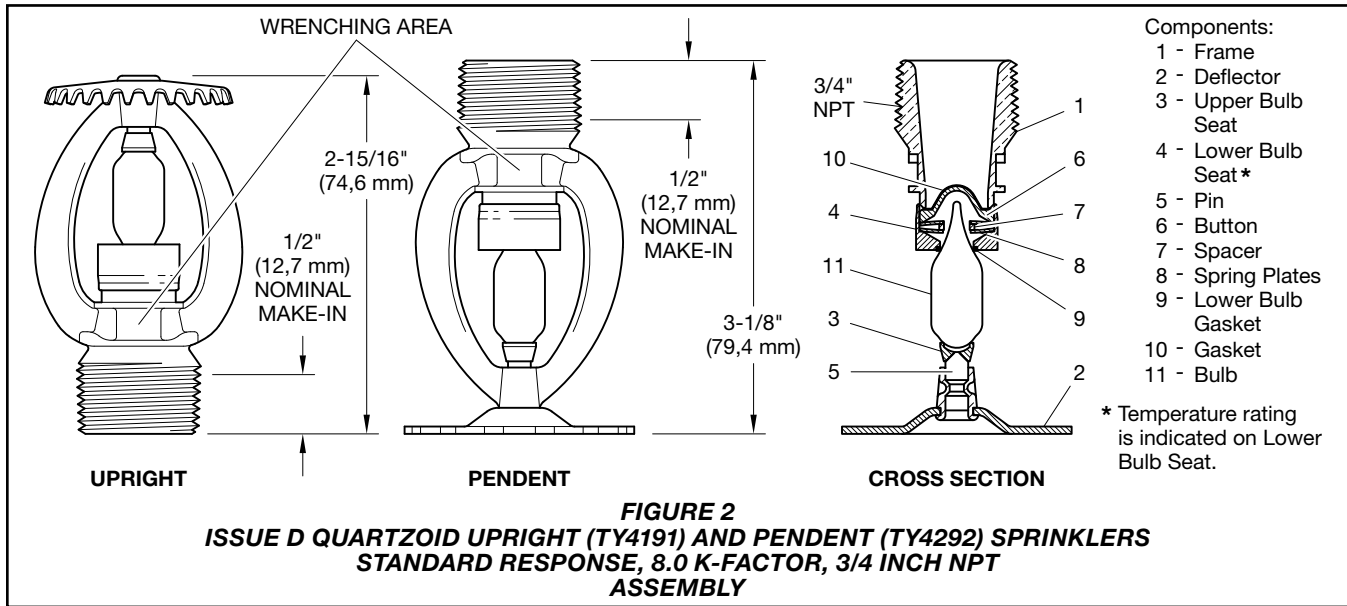
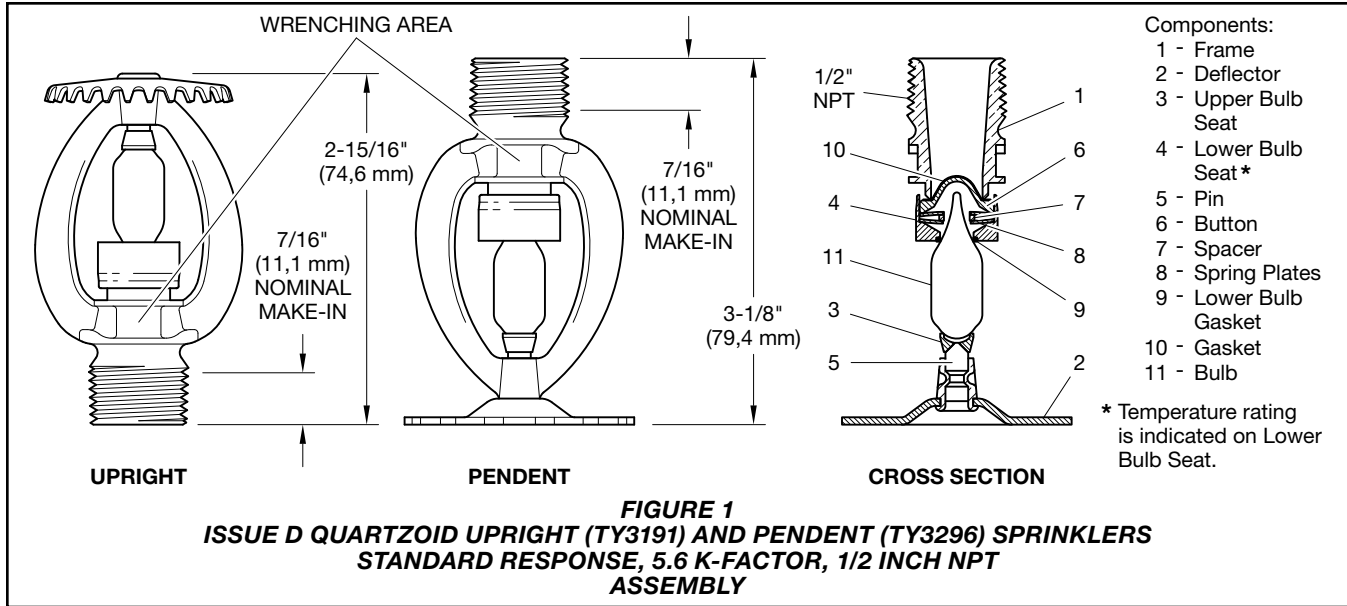

Technical Data

Approvals

UL and C-UL Listed
 FM and LPCB Approved

(Refer to Table A for complete approval information, including corrosion-resistant status.)

Maximum Working Pressure

175 psi (12,1 bar)

Discharge Coefficients

K=5.6 gpm/psi^{1/2} (80,6 lpm/bar^{1/2})
 K=8.0 gpm/psi^{1/2} (115,2 lpm/bar^{1/2})

Temperature Ratings

Refer to Table A

Finishes

Refer to Table A

Physical Characteristics

Frame	Bronze
Deflector	Bronze
Bulb Seats	Bronze
Pin	Bronze
Button	Bronze
Spacer	Bronze
Spring Plates	INCONEL
Gaskets	Copper
Bulb (11 mm dia.)	Glass

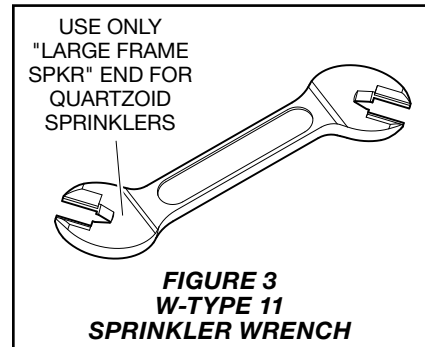

K-FACTOR	SPRINKLER TYPE	TEMPERATURE RATING	BULB LIQUID COLOR	SPRINKLER FINISH ⁵		
				NATURAL BRASS	CHROME PLATED	LEAD COATED
5.6 1/2 in. NPT	UPRIGHT (TY3191) and PENDENT (TY3296)	400°F (204°C)	Black	1, 2, 3	1, 2, 3	1, 2
		500°F (260°C)	Black	1, 2, 3, 4		
		650°F (343°C)	Black	3	N/A	
8.0 3/4 in. NPT	UPRIGHT (TY4191) and PENDENT (TY4292)	400°F (204°C)	Black	1, 2		1, 2
		500°F (260°C)	Black			

Notes:
1. UL Listed
2. C-UL Listed
3. FM Approved
4. LPCB Approved
5. Where Lead Coated sprinklers are noted to be UL and C-UL Listed, the sprinklers are UL and C-UL Listed as Corrosion Resistant Sprinklers
N/A – Not Applicable

TABLE A
ISSUE D QUARTZOID UPRIGHT & PENDENT SPRINKLERS
LABORATORY LISTINGS AND APPROVALS

Design Criteria

TYCO Issue D QUARTZOID 5.6K and 8.0K Upright and Pendent, Standard Response, Standard Coverage Sprinklers are intended for fire protection systems designed in accordance with the standard installation rules recognized by the applicable listing or approval agency (UL Listing is based on the requirements of NFPA 13, and FM Approval is based on the requirements of FM Approvals' Loss Prevention Data Sheets).

Operation

The glass bulb contains a fluid which expands when exposed to heat. When the rated temperature is reached, the fluid expands sufficiently to shatter the glass bulb, allowing the sprinkler to activate and water to flow.

Installation

Issue D QUARTZOID 5.6K and 8.0K Upright and Pendent, Standard Response, Standard Coverage Sprinklers must be installed in accordance with this section.

NOTICE

Do not install any bulb type sprinkler if the bulb is cracked or there is a loss of liquid from the bulb. With the sprinkler held horizontally, a small air bubble should be present. The diameter of the air bubble is approximately 1/4 inch (6,4 mm).

General Instructions

A leak-tight 1/2 in. NPT sprinkler joint should be obtained by applying a maximum-to-minimum torque of 7 to 14 lb-ft (9,5 to 19,0 N·m). A leak-tight 3/4 in. NPT sprinkler joint should be obtained by applying a maximum-to-minimum torque of 10 to 20 lb-ft (13,4 to 26,8 N·m). Higher levels of torque may distort the sprinkler inlet and cause leakage or impairment of the sprinkler.

Step 1. Install upright sprinklers in the upright position; install pendent sprinklers in the pendent position.

Step 2. With pipe thread sealant applied to the pipe threads, hand-tighten the sprinkler into the sprinkler fitting.

Step 3. Tighten the sprinkler into the sprinkler fitting using only the W-Type 11 Sprinkler Wrench (Ref. Figure 3). With reference to Figure 1 or 2, apply the W-Type 11 Sprinkler Wrench is to the wrenching area.

P/N 51 — XXX — X — XXX

		SIN	SPRINKLER FINISH		TEMPERATURE RATING	
036	5.6K UPRIGHT (1/2 in. NPT)	TY3191	1	NATURAL BRASS	400	400°F (204°C)
040	5.6K PENDENT (1/2 in. NPT)	TY3296	7	LEAD COATED*	500	500°F (260°C)
136	8.0K UPRIGHT (3/4 in. NPT)	TY4191	9	CHROME PLATED	650	650°F (343°C)**
140	8.0K PENDENT (3/4 in. NPT)	TY4292				

*400°F and 500°F only **5.6K only

TABLE B
ISSUE D QUARTZOID UPRIGHT AND PENDENT SPRINKLERS, STANDARD RESPONSE
PART NUMBER SELECTION

Care and Maintenance

Issue D QUARTZOID 5.6K and 8.0K Upright and Pendent, Standard Response, Standard Coverage Sprinklers must be maintained and serviced in accordance with this section.

Before closing a fire protection system control valve for maintenance work on the fire protection system that it controls, permission to shut down the affected fire protection system must be obtained from the proper authorities and all personnel who may be affected by this action must be notified.

The owner must assure that the sprinklers are not used for hanging any objects and that the sprinklers are only cleaned by means of gently dusting with a feather duster; otherwise, non-operation in the event of a fire or inadvertent operation may result.

Sprinklers which are found to be leaking or exhibiting visible signs of corrosion must be replaced.

Automatic sprinklers must never be painted, plated, coated, or otherwise altered after leaving the factory. Modified sprinklers must be replaced.

Sprinklers that have been exposed to corrosive products of combustion, but have not operated, should be replaced if they cannot be completely cleaned by wiping the sprinkler with a cloth or by brushing it with a soft bristle brush.

Care must be exercised to avoid damage to the sprinklers - before, during, and after installation. Sprinklers damaged by dropping, striking, wrench twist/slippage, or the like, must be replaced. Also, replace any sprinkler that has a cracked bulb or that has lost liquid from its bulb. Refer to the Installation section for more information.

The owner is responsible for the inspection, testing, and maintenance of their fire protection system and devices in compliance with this document, as well as with the applicable standards of the NATIONAL FIRE PROTECTION ASSOCIATION (e.g., NFPA 25), in addition to the standards of any authorities having jurisdiction. Contact the installing contractor or product manufacturer with any questions.

Automatic sprinkler systems are recommended to be inspected, tested, and maintained by a qualified Inspection Service in accordance with local requirements and/or national codes.

Limited Warranty

For warranty terms and conditions, visit www.tyco-fire.com.

Ordering Procedure

Contact your local distributor for availability. When placing an order, indicate the full product name, including description and Part Number (P/N).

Sprinkler Assemblies with NPT Thread Connections

Specify: Issue D QUARTZOID (specify SIN), (specify K-factor), (specify Upright or Pendent) Sprinklers, Standard Response, Standard Coverage, (specify) temperature rating, (specify) finish, P/N (specify from Table B)

Sprinkler Wrench

Specify: W-Type 11 Sprinkler Wrench, P/N 56-452-1-001



Worldwide
Contacts | www.tyco-fire.com

TFP690 Change History Appendix

ISSUE DATE	NOTES
08-22	Page 1, added QR code and URL to allow convenient access to electronic version from printed document; Page 4, changed corporate address and telephone number to 1467 Elmwood Avenue, Cranston, RI 02910 Telephone +1-401-781-8220, formerly 1400 Pennbrook Parkway, Lansdale, PA 19446 Telephone +1-215-362-0700.
08-18	Updated Tyco® branding and document format; Added Johnson Controls copyright; Added disclaimer stating specifications and information subject to change without notice; Added reference to Regulatory and Health Warning Technical Data Sheet TFP2300.
10-16	Corrected SIN numbers for 8.0K sprinklers in Table A: Upright to TY4191, formerly shown as TY3191; Pendent to TY4292, formerly shown as TY3296.
07-15	Added LPCB Approved for TY3296 and TY3191 sprinklers in 500°F (260°C) Temperature Rating and Brass finish.
09-09	Clarified 650°F (343°C) Temperature Rating.
07-07	Corrected SIN number for 5.6K pendent sprinkler to TY3296, formerly shown as TY3291.
04-06	New Technical Data Sheet TFP690 describes Issue D Quartzoid, High Temperature Upright and Pendent Sprinklers.